CONSTRUCTION MANUAL FOR DESIGNERS AND BUILDERS

Dincel Construction System Pty Ltd
101 Quarry Road
ERSKINE PARK NSW 2759
PO Box 104, ST CLAIR NSW 2759
Phone: (612) 9670 1633 Fax: (612) 9670 6744
Email: construction@dincel.com.au

COPYRIGHT

© Dincel Construction System Pty Ltd

All rights reserved. No part of the information contained in this document may be reproduced or copied in any form or by any means without written permission from Dincel Construction System Pty Ltd.

DISCLAIMER

The information contained in this document is intended for the use of suitably qualified and experienced architects and engineers and other building professionals. This information is not intended to replace design calculations or analysis normally associated with the design and specification of buildings and their components. The information contained in this document is not project specific. Building professionals are required to assess construction site conditions and provide design/details and appropriate safe work method statements accordingly. Dincel Construction System Pty Ltd accepts no liability for any circumstances arising from the failure of a specifier or user of any part of Dincel Construction System to obtain appropriate project specific professional advice about its use and installation or from failure to adhere to the requirements of appropriate Standards, Codes of Practice, Worker Health & Safety Act and relevant Building Codes.

SEPTEMBER 2019 MANUAL

Dincel's ISO 9705, BS 8414/AS 5113 and AS 1530.4 test results confirm Dincel's ongoing compliance supplementing the topics nominated in Dincel's CodeMark Certificate of Conformity.

Dincel's CodeMark Certificate of Conformity (No: CM40220) confirms our products conformity as a Structural Concrete Wall Element under the following clauses of the NCC.

- **Performance Requirement CP2** – Relevant performance requirement for non-combustible external wall construction
- **Specification C1.10** - Fire Hazard Properties
- **Performance Requirement CP8** - The use of fire collars, and the use of fire rated sealants at wall-to-wall and wall-to-slab junctions
- **Specification C1.1** - Fire Resistance Periods - Insulation and Integrity (Structural Adequacy is to be calculated by the project structural design engineer)
- **G5.2** - Bush Fire Zones
- **Performance Requirements CP1 and CP4.**

Uses other than as a Structural Concrete Wall Element, in relation to the above compliance clauses, are outside of the scope of CodeMark Certificate of Conformity (No: CM40220).

IMPORTANT NOTE

1. THIS MANUAL DOES NOT COVER BASEMENT WALLS UNDER SUBMERGED CONDITIONS (i.e. FOOTINGS BELOW PERMANENT WATER TABLE). REFER 275 DINCEL MANUAL FOR BASEMENTS UNDER SUBMERGED CONDITIONS.

2. GUIDE TRACK P-G USE:

DO NOT USE P-G UNDERNEATH THE BASEMENT WALLS, WATER TANKS, SHEAR WALLS (EG, LIFT/STAIR SHAFTS)

INDEX

Items C, F and I must be read by anyone seeking guidance from this Manual.

GENERAL INFORMATION

- (A) What Is It
- (B) Where It Can Be Used
- (C) **The Use of This Manual**
- (D) Available Dincel Profiles; Wall Assemblies

INFORMATION FOR ARCHITECTS

- (E) The Dincel Wall Methodology, Wall Set-Out, Architectural Detailing
- (F) **Finishes**
- (G) Termite Treatment
- (H) Services
- (I) Fire Sealant/Collar Use At Abutting Fire Walls

INFORMATION FOR INSTALLERS/ENGINEERS

- (J) **Installer's Dincel Product Acceptance Criteria – IMPORTANT**
- (K) Recommendation for Installation, Concrete Mix Design and Placement
- (L) Detailing:
 - Structural Walls
 - Typical Footings
 - Sloping Sites
 - Tanks
 - Pits, Trenches
 - Steel Bar Positioning
 - Corners
 - Retaining Walls
 - Basement Walls
 - Swimming Pools
 - Typical Details

BUILDING AND DESIGN WITH DINCEL[®] - WALL

(A) WHAT IS IT ?

DCS is a waterproof polymer formwork for walls/columns that are available in thicknesses of 110mm, 155mm, 200mm and 275mm. Refer 275 Dincel Manual for 275mm thick walls. Forms are manufactured to suit any custom lengths between 1.8 metres and 7.95 metres.

(B) WHERE CAN IT BE USED ?

Building Walls	Private residences, villas and townhouses. Basements, lift-stair shafts, party-corridor-façade walls of apartments, offices, retail, industrial, warehouses, hospitals, shopping centres. Excellent corrosion resistance for marine and agricultural building structures such as poultry, piggeries, fertiliser, sewerage plants, irrigation, water management channels and controlling devices. Replacement of conventional precast, tilt-up and masonry block walls.
Retaining Walls	Basement walls above permanent water table, earth retaining, mining, erosion control, river embankment protection, sea walls. (Refer 275 Dincel Manual for below water table condition).
Storage Tanks	Water (detention, retention, stormwater pits), fish farming tanks, waste water, sewerage, sludge, petrol, manure, grain and contaminated soil.
Special Uses	Bushfire Prone Areas, mine subsidence areas, sound barriers, prevent the migration of contaminated ground water, construction in acid sulphate soils, energy free flood levies to protect township or generate flood free developable lands.

(C) THE USE OF THIS MANUAL AND DISCLAIMER

The users of this manual must read the Dincel disclaimer shown on page 1 and Index Item (I) Installer's Dincel Product Acceptance Criteria of this manual. The design and detailing principles of each project may change depending on many engineering reasons, including ground conditions. It is the project's consultant's responsibility to design and adopt suitable detailing for each project. The installers must require specific project detailing for each and every project. **The detailing shown in this manual shall be treated as general guidance and not project specific.**

The Dincel users and their consultants should particularly refer to Dincel's document titled "**Dincel Product Information**" which is placed on the Dincel website. The project's conditions (including topography, excavation depth, proximity to water sources, ground water conditions) necessitate the project's building professionals to decide on the Dincel wall/slab/footing junctions details to be adopted. The detail recommended for "below permanent water condition" for basement walls of this manual offer significantly minimised risk at the footing/Dincel wall junction. If the designer wishes to minimise the risk, the appropriate details are required to be adopted. **It must be accepted that the best waterproofing detailing may fail unless it is executed in a good workmanship manner. For this reason, Dincel Construction System Pty Ltd not being the installer, shall not take any responsibility for installation matters, including waterproofing.**

The Worker Health & Safety Act 2011 was effective from 01st January 2012. The readers shall read this manual and Dincel's document titled "**Dincel Solution for Construction Safety**" which is available on the Dincel website.

(D) AVAILABLE DINCEL PROFILES; WALL ASSEMBLIES

110mm SERIES PROFILES

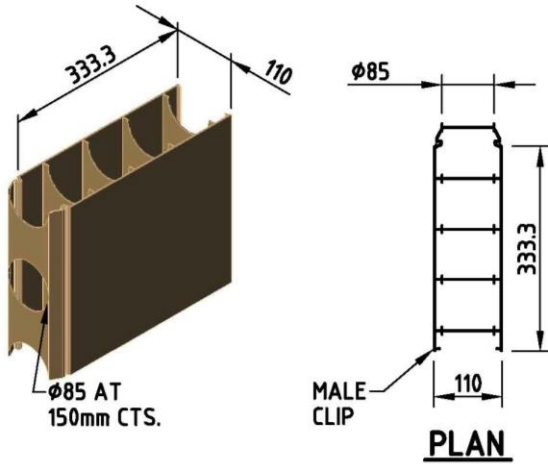

110P-1 110mm MAIN PROFILE

Description: The 110P-1 profile is the main profile within the 110mm range. The main profile can be installed in vertical or horizontal directions.

Method of Sale: Custom made profiles in heights between 1800mm to 7950mm
Refer to order form for stock heights

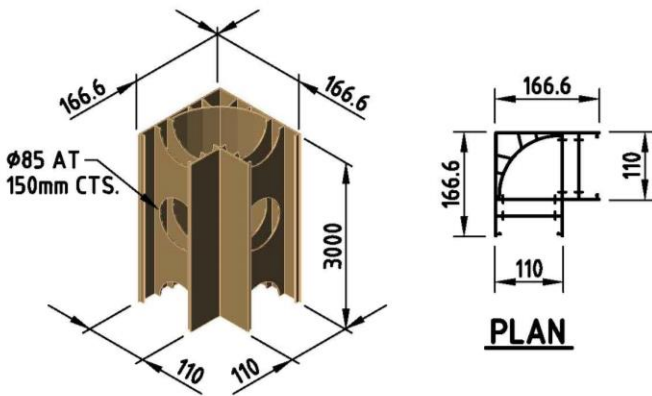

110P-3 CORNER PROFILE

Description: The 110P-3 profile achieves 90° wall corner.

Method of Sale: Available only in stock lengths of 3000mm.

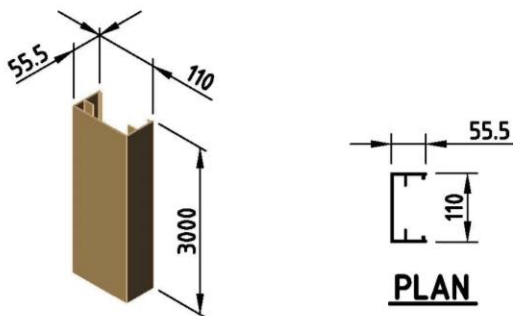

110P-EC END CAP

Description: The 110P-EC is used to finish off the end of a wall installed vertically. The 110P-EC extends the overall wall length of the wall by 55.5mm.

Method of Sale: Available only in stock lengths of 3000mm.

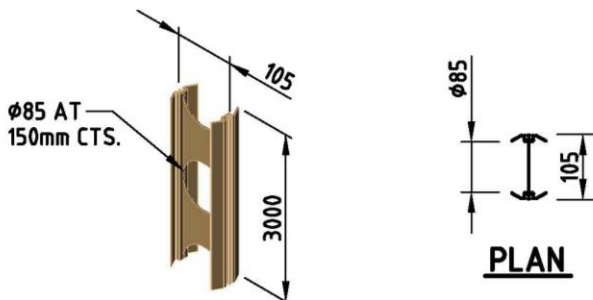

110P-J JOINER

Description: The 110P-J profile is used to join 110P-1 main profiles to each other through their male clips.

Method of Sale: Available only in stock lengths of 3000mm.

110mm SERIES PROFILES

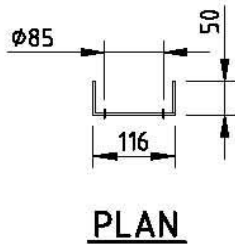
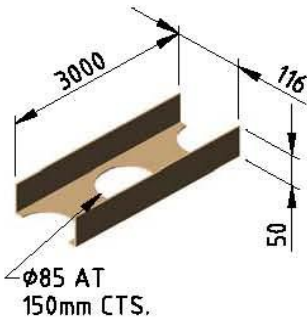

110P-G GUIDE

Description: The 110P-G is used as a guide to hold the bottom of walls during concrete pouring. The 110P-G is secured to the slab or footing with concrete nails.

Method of Sale: Available only in stock lengths of 3000mm.

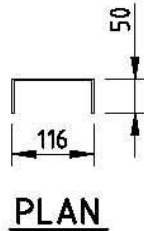
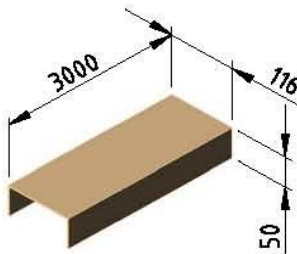

110P-TC TOP CAP

Description: The 110P-TC is used as a capping on top or end of a wall installed vertically or horizontally. This profile is essentially the 110P-G without any holes.

Method of Sale: Available only in stock lengths of 3000mm.

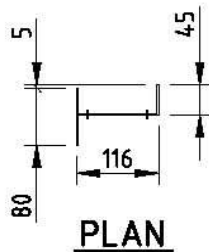
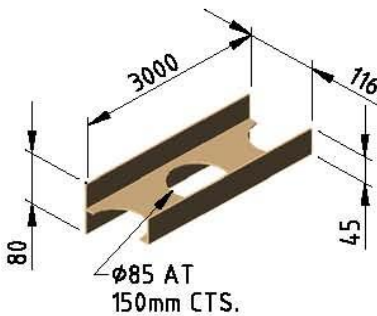

110P-EG EDGE GUIDE

Description: The 110P-EG is used at floor or footing slab edge to start the wall over. Or can be also be used at window jambs, sill and head.

Method of Sale: Available only in stock lengths of 3000mm.

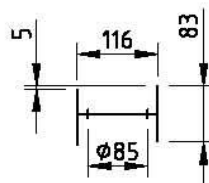
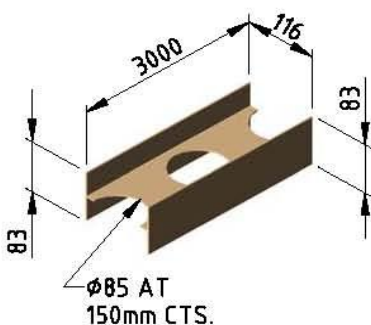

110P-WS WINDOW SILL / WALL SPLICER

Description: The 110P-WS can either be used as a sill and head for the windows or a wall splicer to extend the profiles installed in vertical or horizontal directions.

Method of Sale: Available only in stock lengths of 3000mm.

110mm SERIES PROFILES

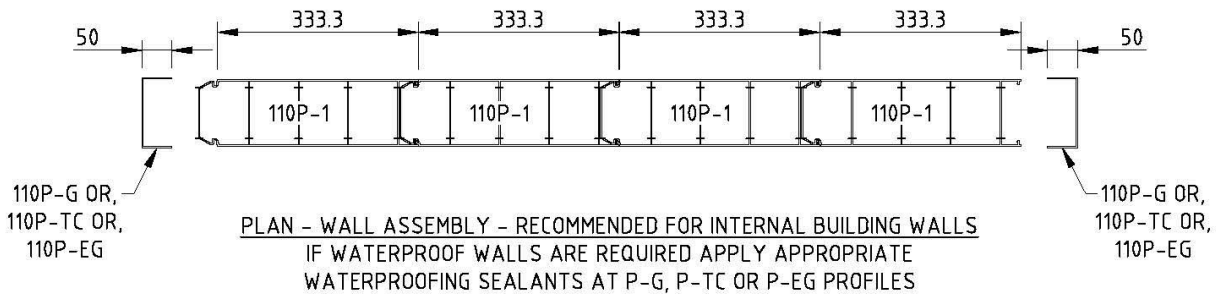
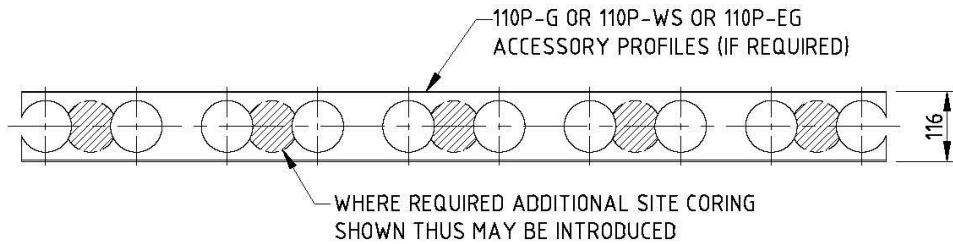
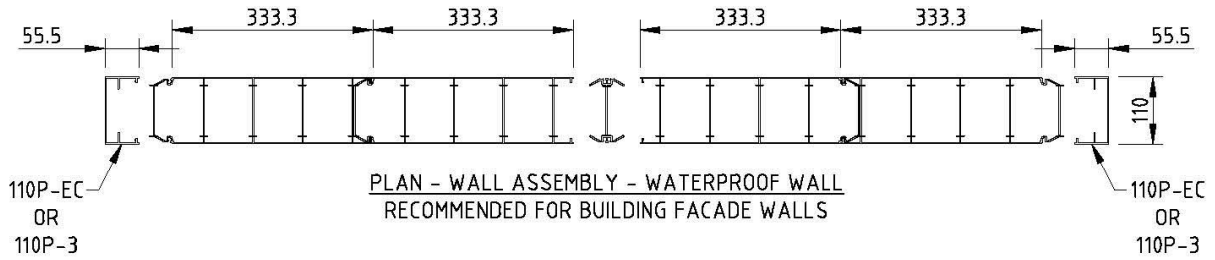

PLAN - PROFILES FOR WALL ASSEMBLY

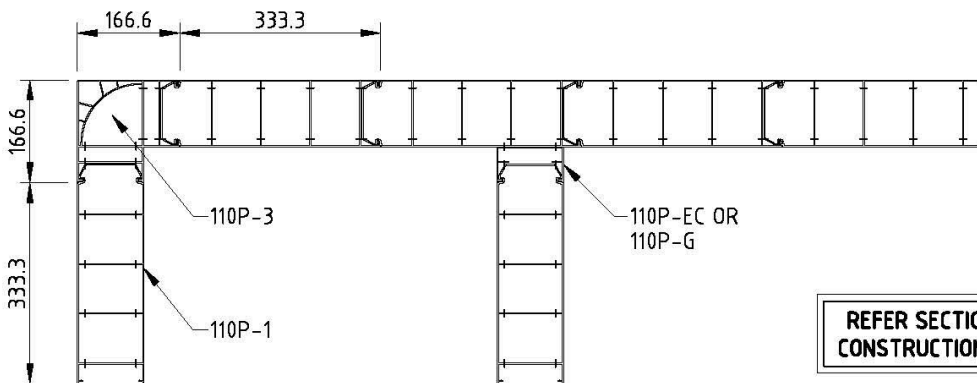

**REFER SECTION (K) - 5 FOR
CONSTRUCTION TOLERANCES**

**110mm CORNER
ASSEMBLY**

**110mm T-JUNCTION
ASSEMBLY**

155mm SERIES PROFILES

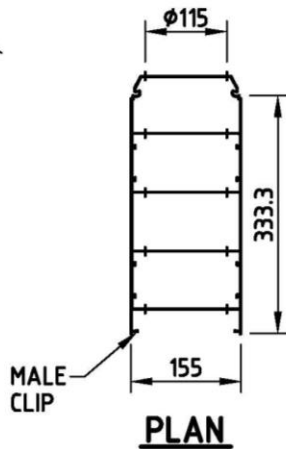
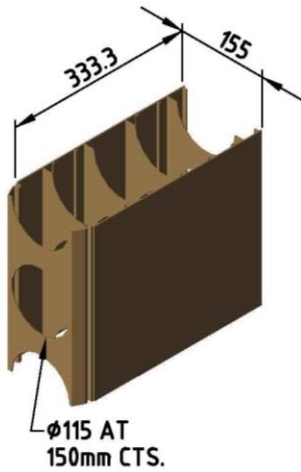

155P-1 155mm MAIN PROFILE

Description: The 155P-1 profile is the main profile within the 155mm range. The main profile can be installed in vertical or horizontal directions.

Method of Sale: Custom made profiles in heights between 1800mm to 7950mm. Refer to order form for stock heights.

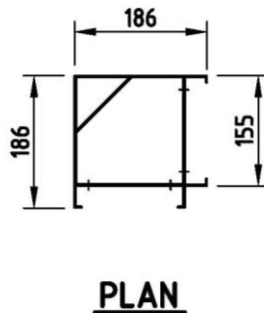

155P-3 155mm CORNER PROFILE

Description: The 155P-3 profile achieves 90° wall corner.

Method of Sale: Available only in stock lengths of 3000mm.

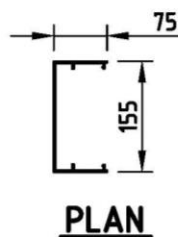
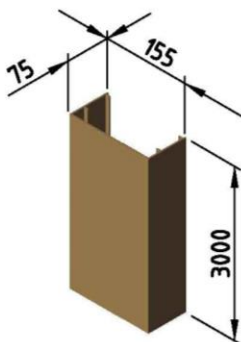

155P-EC END CAP

Description: The 155P-EC is used to finish off the end of a wall installed vertically. The 155P-EC extends the overall wall length of the wall by 75mm.

Method of Sale: Available only in stock lengths of 3000mm.

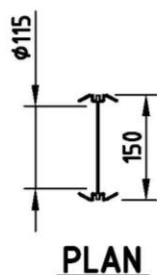
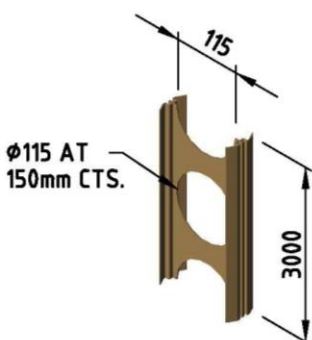

155P-J JOINER

Description: The 155P-J profile is used to join 155P-1 main profiles to each other through their male clips.

Method of Sale: Available only in stock lengths of 3000mm.

155mm SERIES PROFILES

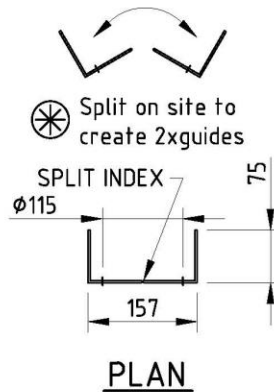
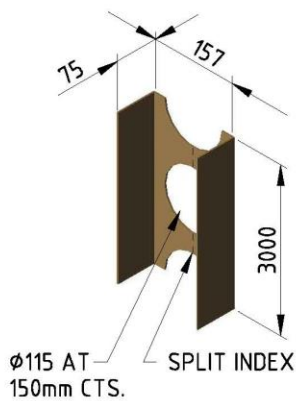

155P-G GUIDE Split on site to create 2xguides

Description: The 155P-G is used as a guide to hold the bottom of walls during concrete pouring. The 155P-G is secured to the slab or footing with concrete nails.

Method of Sale: Available only in stock lengths of 3000mm.

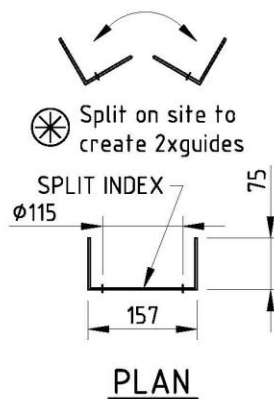
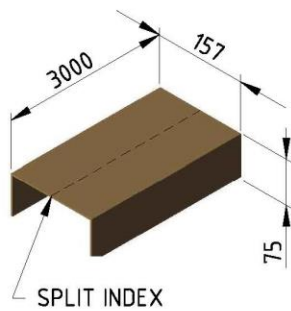

155P-TC TOP CAP Split on site to create 2xguides

Description: The 155P-TC is used as a capping on top or end of a wall installed vertically or horizontally. This profile is essentially the 155P-G without any holes.

Method of Sale: Available only in stock lengths of 3000mm.

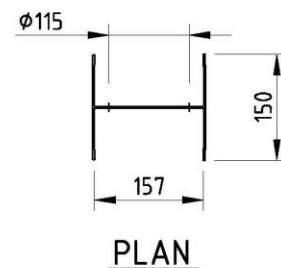
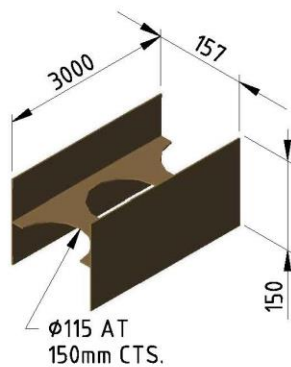

155P-WS WINDOW SILL/ WALL SPLICER

Description: The 155P-WS can either be used as a sill and head for the windows or a wall splicer to extend the profiles installed in vertical or horizontal directions.

Method of Sale: Available only in stock lengths of 3000mm.

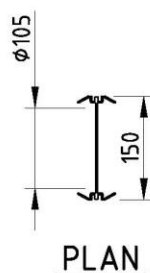
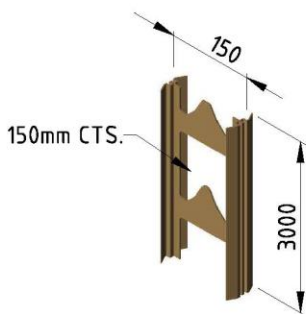

155P-HRC HORIZONTAL REO-CLIP

Description: Horizontal steel bar locator for walls longer than 3m in length to hold double horizontal bars at each face of Dintel panel.

Method of Sale: Recommended at every 10th Dintel panel (i.e. 3.3m).

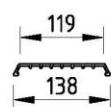
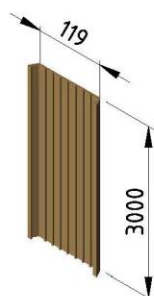

155P-SE STOP END

Description: Used to stop concrete pouring at the male end of 155P-1 main profile by sliding into the grooves of main profile P-1, no screws are required.

Method of Sale: Available only in stock lengths of 3000mm.

155mm SERIES PROFILES

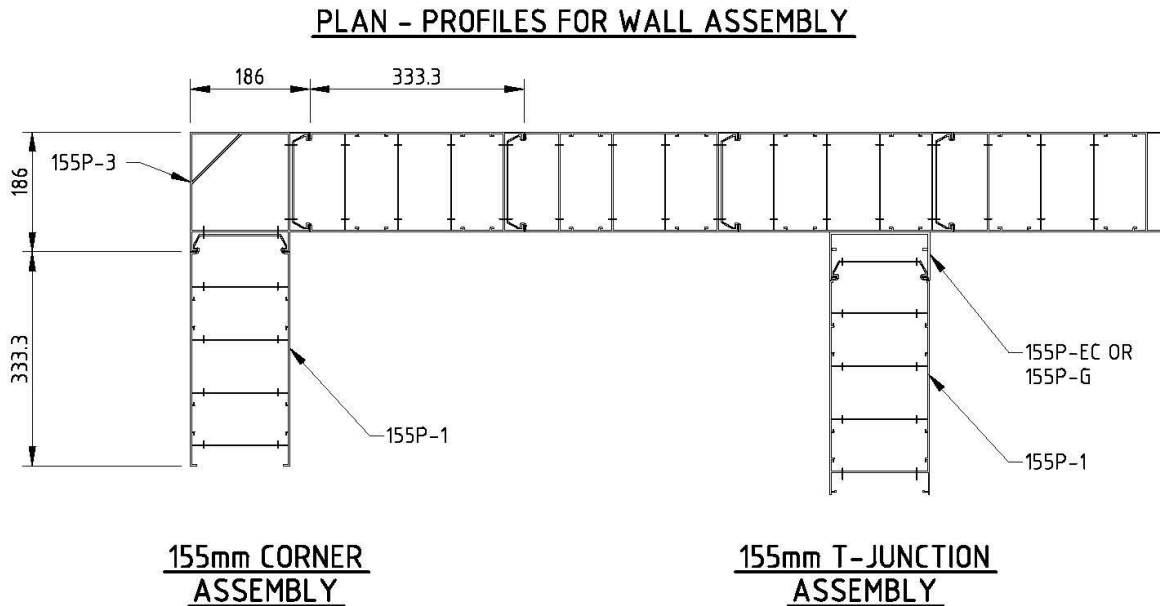
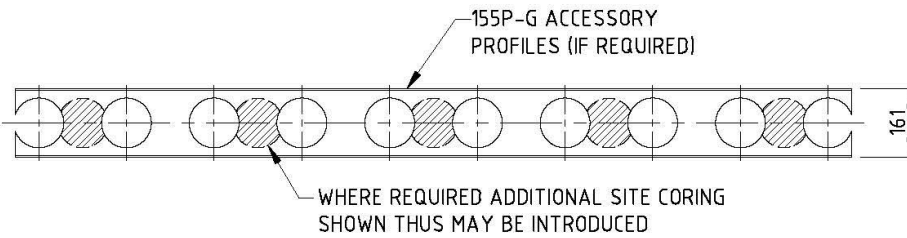
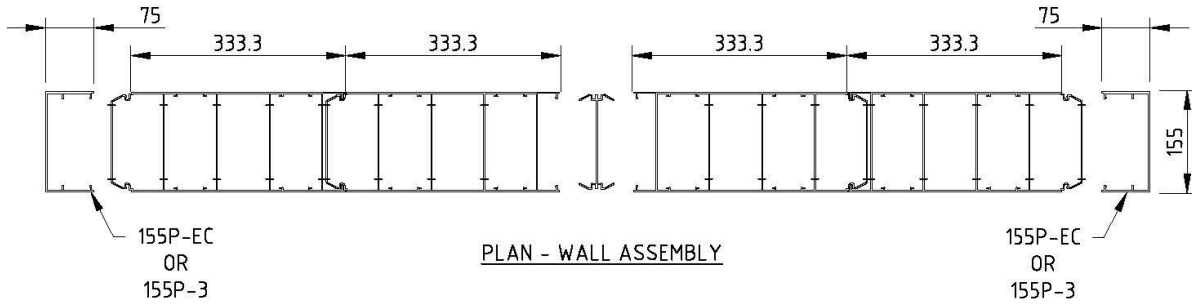

REFER SECTION (K) - 5 FOR
CONSTRUCTION TOLERANCES

200mm SERIES PROFILES

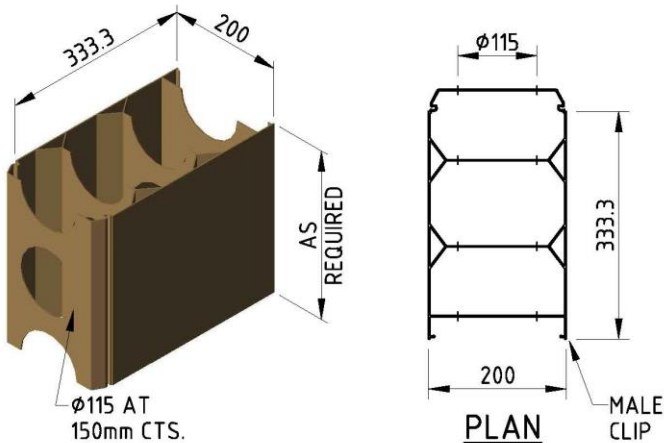

200P-1 200mm MAIN PROFILE

Description: The 200P-1 profile is the main profile within the 200mm range. The main profiles can be installed in vertical or horizontal directions.

Method of Sale: Custom made profiles in heights between 1800mm to 7950mm. Refer to order form for stock heights.

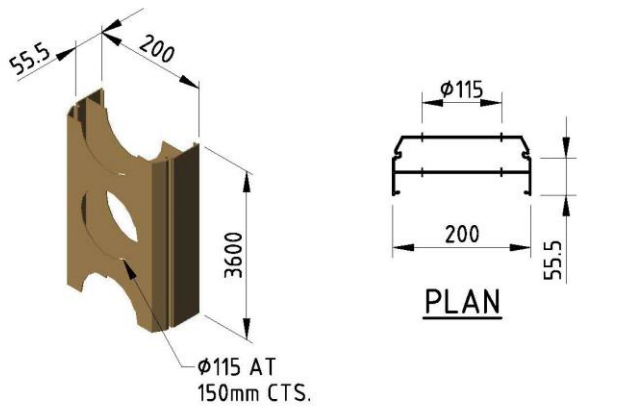

200P-2 55mm SPACER

Description: The 200P-2 profile allows walls to be built with 55.5mm increments. Or alternatively the wall opening sizes can be reduced by adding 200P-2 profiles. When six (6) 200P-2 profiles are connected to each other, it equals one (1) 200P-1.

Method of Sale: Available only in stock lengths of 3600mm.

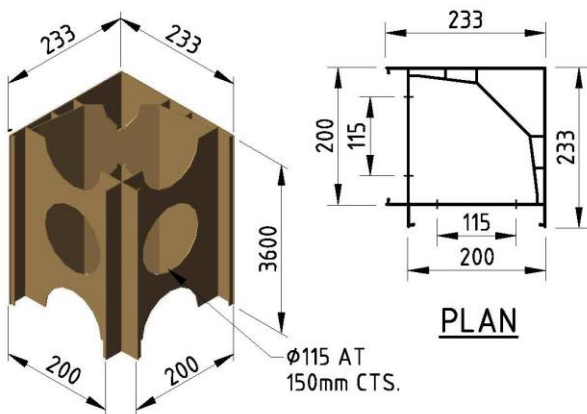

200P-3 CORNER PROFILE

Description: The 200P-3 profile achieves 90° wall corner.

Method of Sale: Available only in stock lengths of 3600mm.

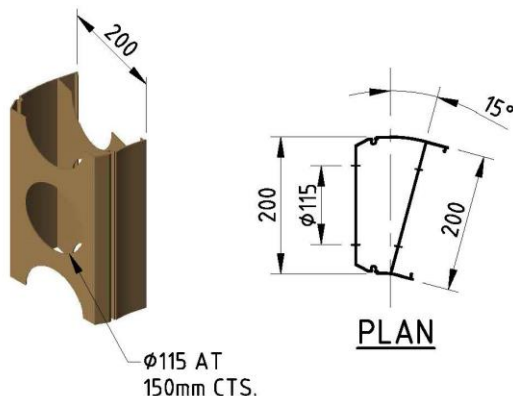

200P-4 ANGLE PROFILE

Description: The 200P-4 profile is further development of the 200P-2 profile which allows corners to be built with 15° increments. The use of the product also allows circular formed or waved shaped walls.

Method of Sale: Available only in stock lengths of 3600mm.

200mm SERIES PROFILES

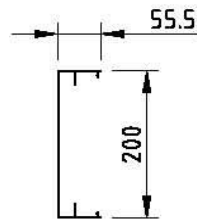
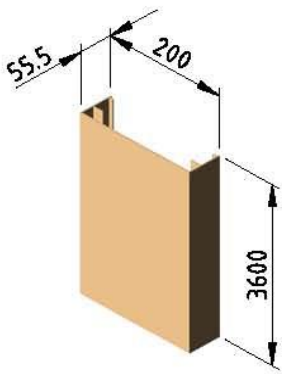

PLAN

200P-EC END CAP

Description: The 200P-EC is used to finish off the end of a wall installed vertically. The 200P-EC extends the overall wall length of the wall by 55.5mm.

Method of Sale: Available only in stock lengths of 3600mm.

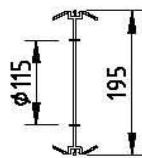
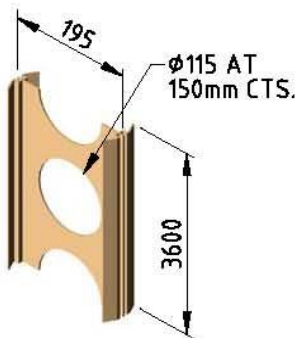

PLAN

200P-J JOINER

Description: The 200P-J profile is used to join 200P-1 main profiles to each other through their male clips.

Method of Sale: Available only in stock lengths of 3600mm.

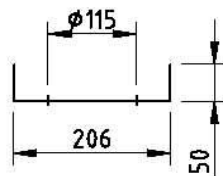
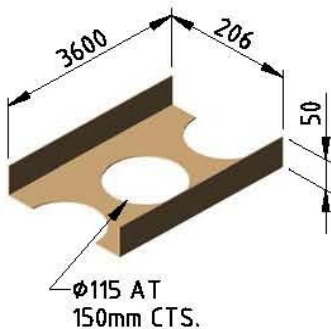

PLAN

200P-G GUIDE

Description: The 200P-G is used as a guide to hold the bottom of walls during concrete pouring. The 200P-G is secured to slab or footing with concrete nails. The use of P-G is not recommended where waterstops are used for waterproofing purposes.

Method of Sale: Available only in stock lengths of 3600mm.

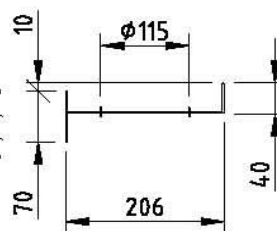
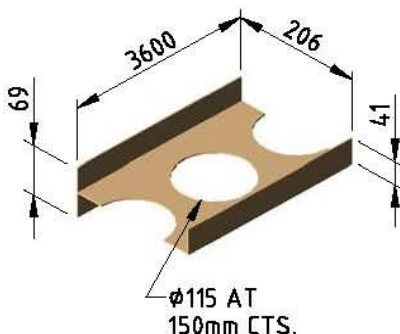

PLAN

200P-EG EDGE GUIDE (For External Walls)

Description: The 200P-EG is used at floor or footing slab edge to start the wall over. Or can be also used at window jambs, sill and head.

Method of Sale: Available only in stock lengths of 3600mm.

200mm SERIES PROFILES

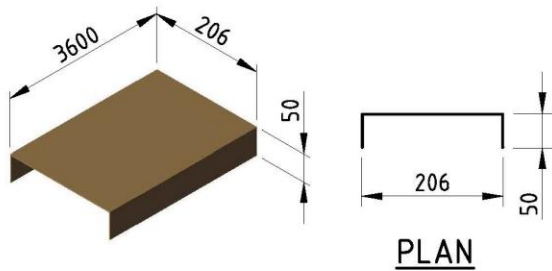

200P-TC TOP CAP

Description: The 200P-TC can be used as a capping on top or end of a wall made out of vertically or horizontally placed 200P-1 main profiles. This profile is essentially the 200P-G without any holes.

Method of Sale: Available only in stock lengths of 3600mm.

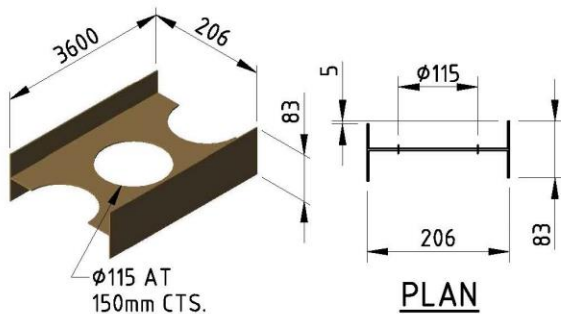

200P-WS WINDOW SILL/WALL SPLICER

Description: The 200P-WS can either be used as a sill and head for the windows or a wall splicer to extend the profiles installed in vertical or horizontal directions.

Method of Sale: Available only in stock lengths of 3600mm.

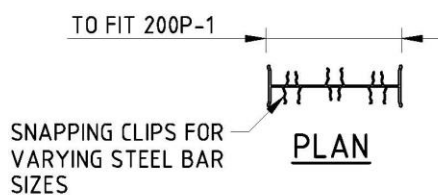

200P-VRC VERTICAL REO-CLIP

Description: Vertical steel bar locator.

Method of Sale: Packs of 100.

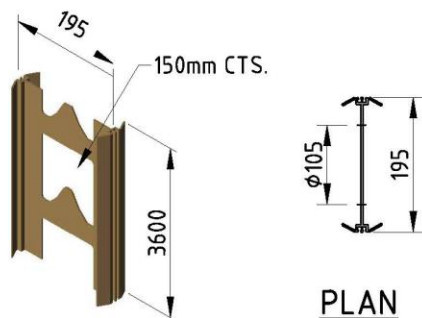

200P-HRC HORIZONTAL REO-CLIP

Description: Horizontal steel bar locator for walls longer than 3m in length to hold double horizontal bars at each face of Dintel panel.

Method of Sale: Recommended at every 10th Dintel panel (i.e. 3.3m).

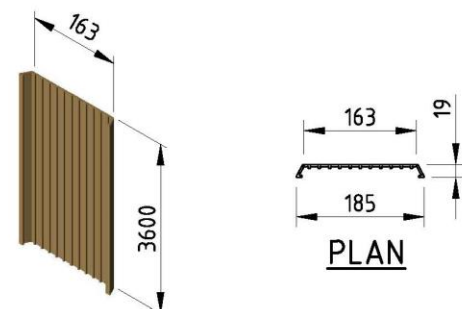

200P-SE STOP END

Description: Used to stop concrete pouring at the male end of 200P-1 main profile by sliding into the grooves of main profile P-1, no screws are required.

Method of Sale: Available only in stock lengths of 3600mm.

PLAN - 200 SERIES WALL ASSEMBLIES

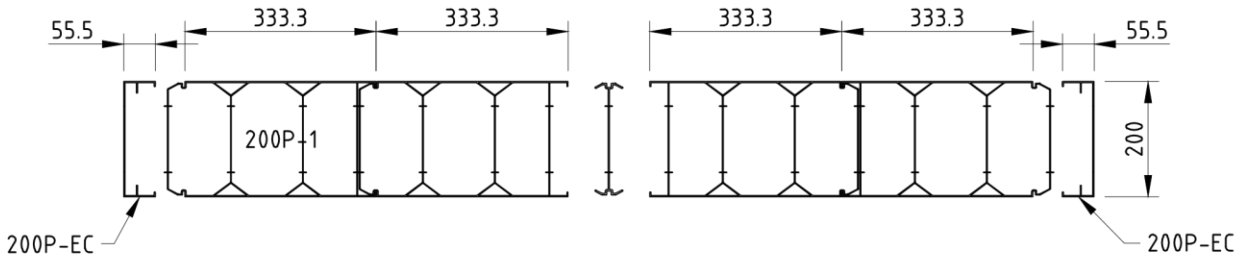

PLAN - WALL ASSEMBLY - WATERPROOF WALL
RECOMMENDED FOR BUILDING BASEMENT/FACADE WALLS

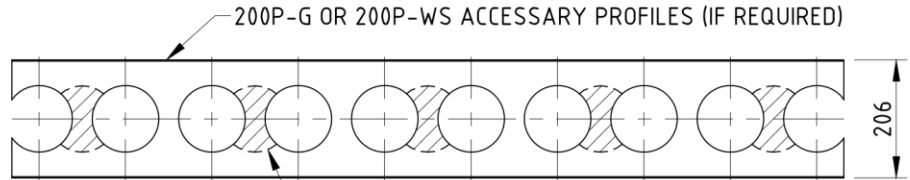

WHERE REQUIRED ADDITIONAL SITE CORING
SHOWN THIS MAY BE INTRODUCED

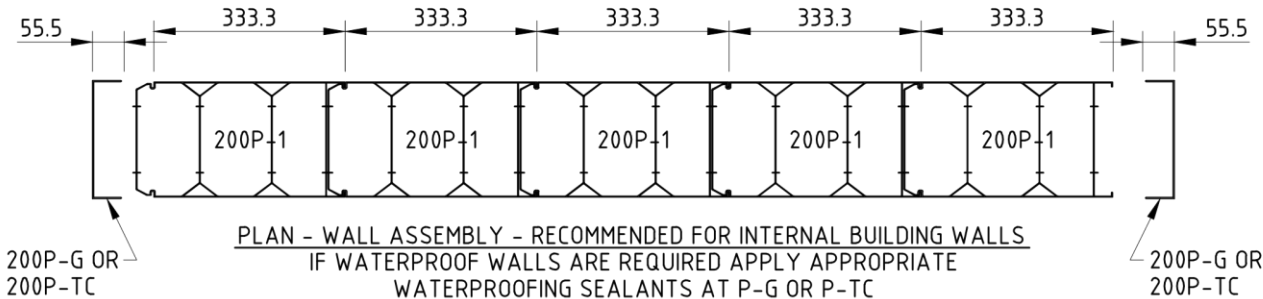

PLAN - WALL ASSEMBLY - RECOMMENDED FOR INTERNAL BUILDING WALLS
IF WATERPROOF WALLS ARE REQUIRED APPLY APPROPRIATE
WATERPROOFING SEALANTS AT P-G OR P-TC

200mm SERIES CORNER ASSEMBLIES

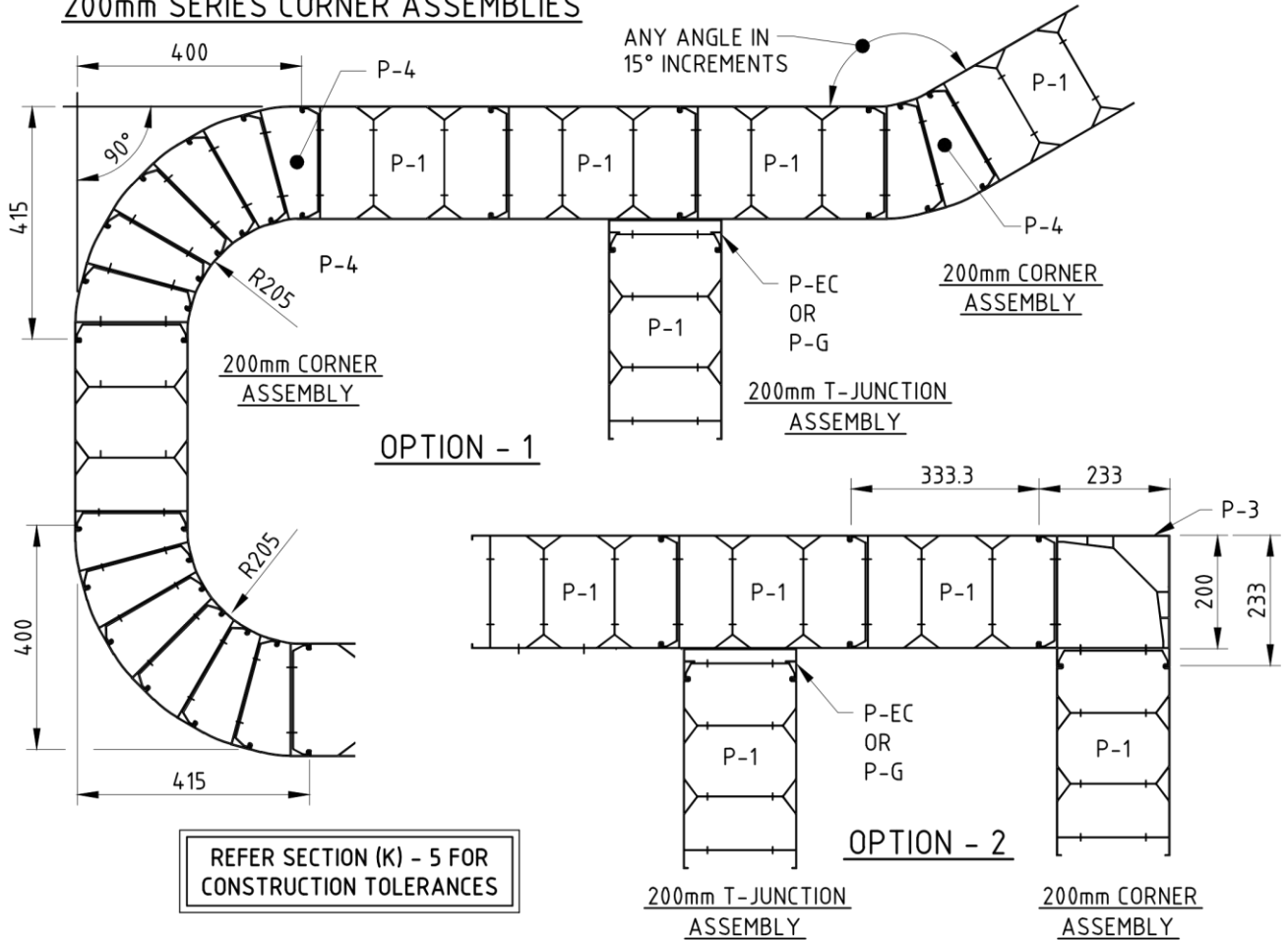

REFER SECTION (K) - 5 FOR
CONSTRUCTION TOLERANCES

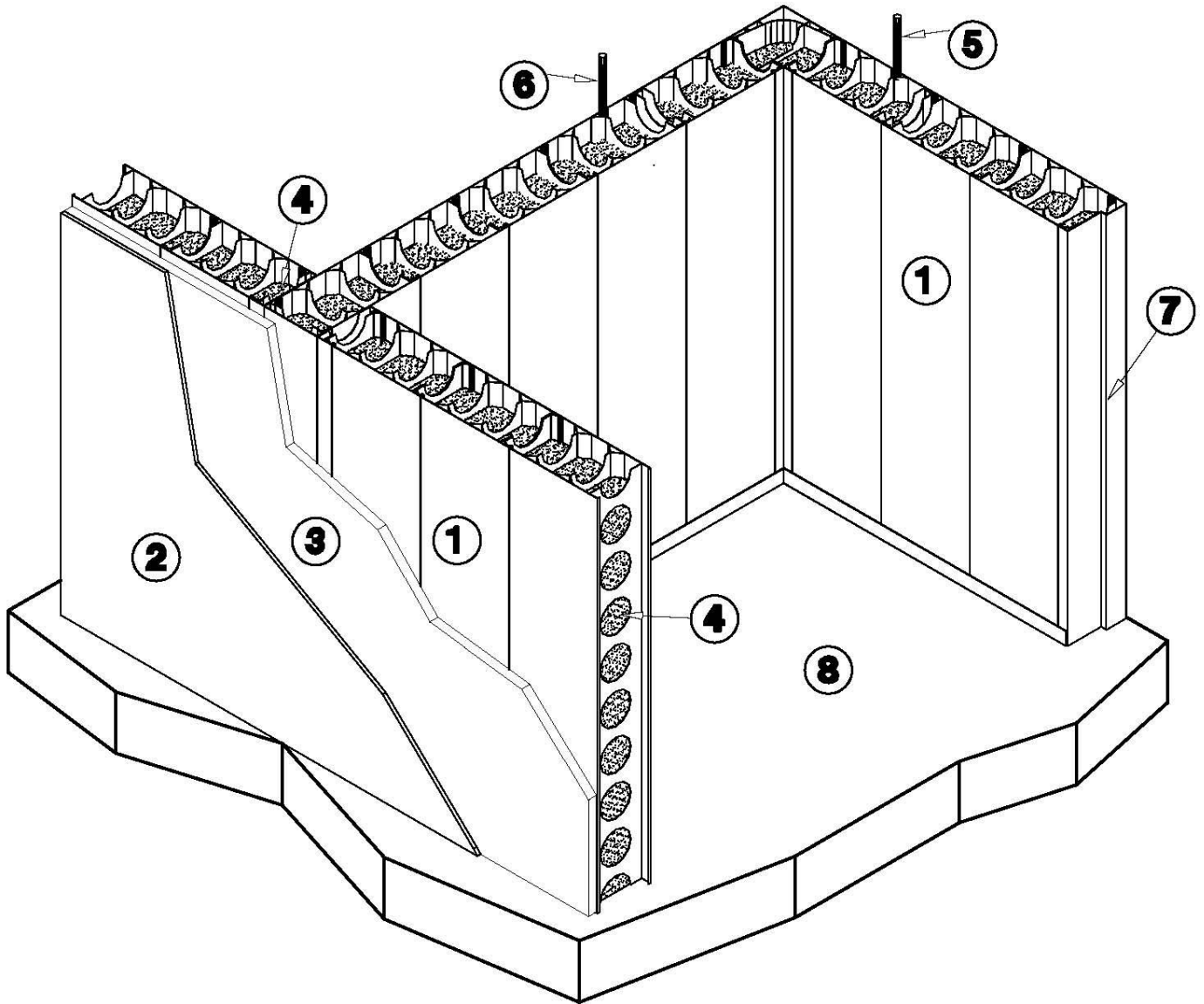

- ① DINCCEL-WALL
- ② Polymer render/plasterboard finish insulation (optional)
- ③ Insulation (optional)
- ④ Concrete
- ⑤ Service Space/electrical, communication cables
- ⑥ Service Space/water pipes
- ⑦ Door Jamb
- ⑧ Floor

FIGURE 2 – DINCCEL® - WALL SYSTEM

(E) THE DINCEL® - WALL METHODOLOGY

The figure below is an example to illustrate the **DINCEL® - WALL** as a building system in a residential development (similar in commercial buildings). The party walls of sole occupancy units and corridor walls are permanent fire and acoustic walls. The party walls can be load bearing or non-load bearing.

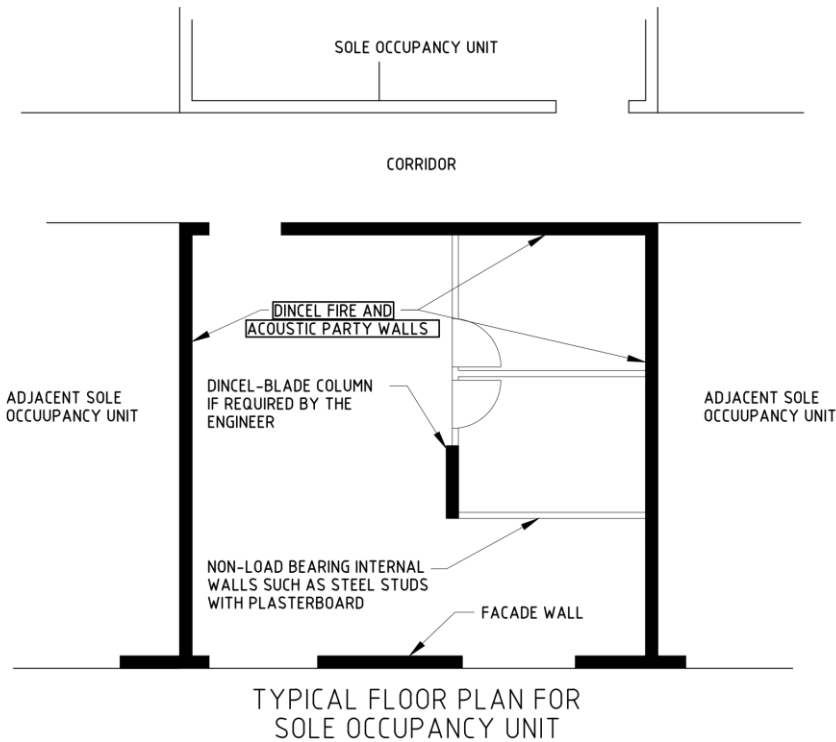
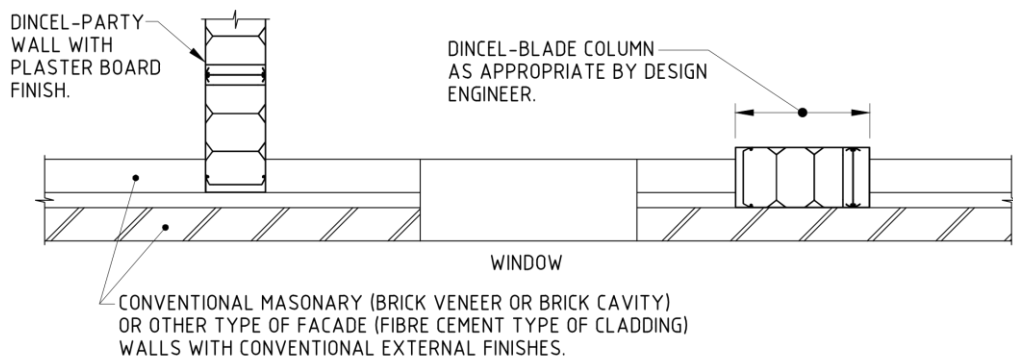
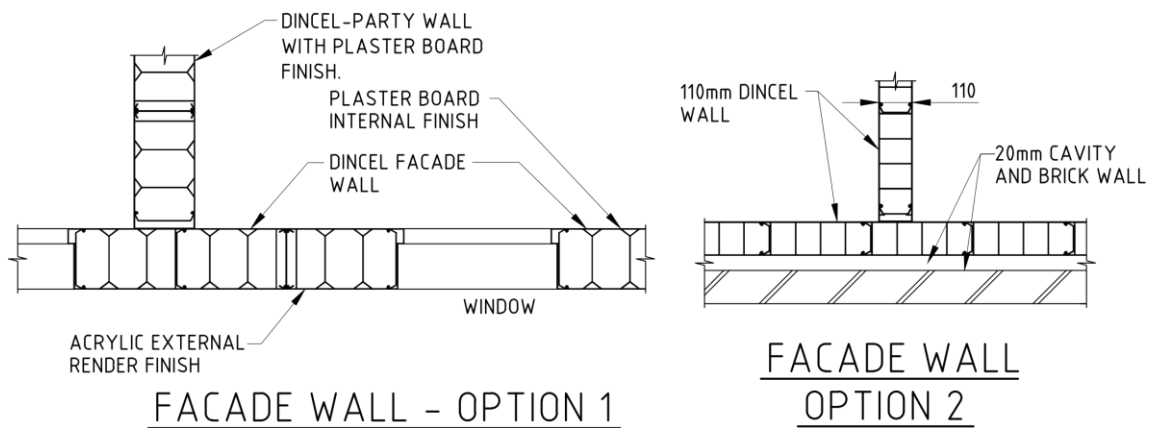
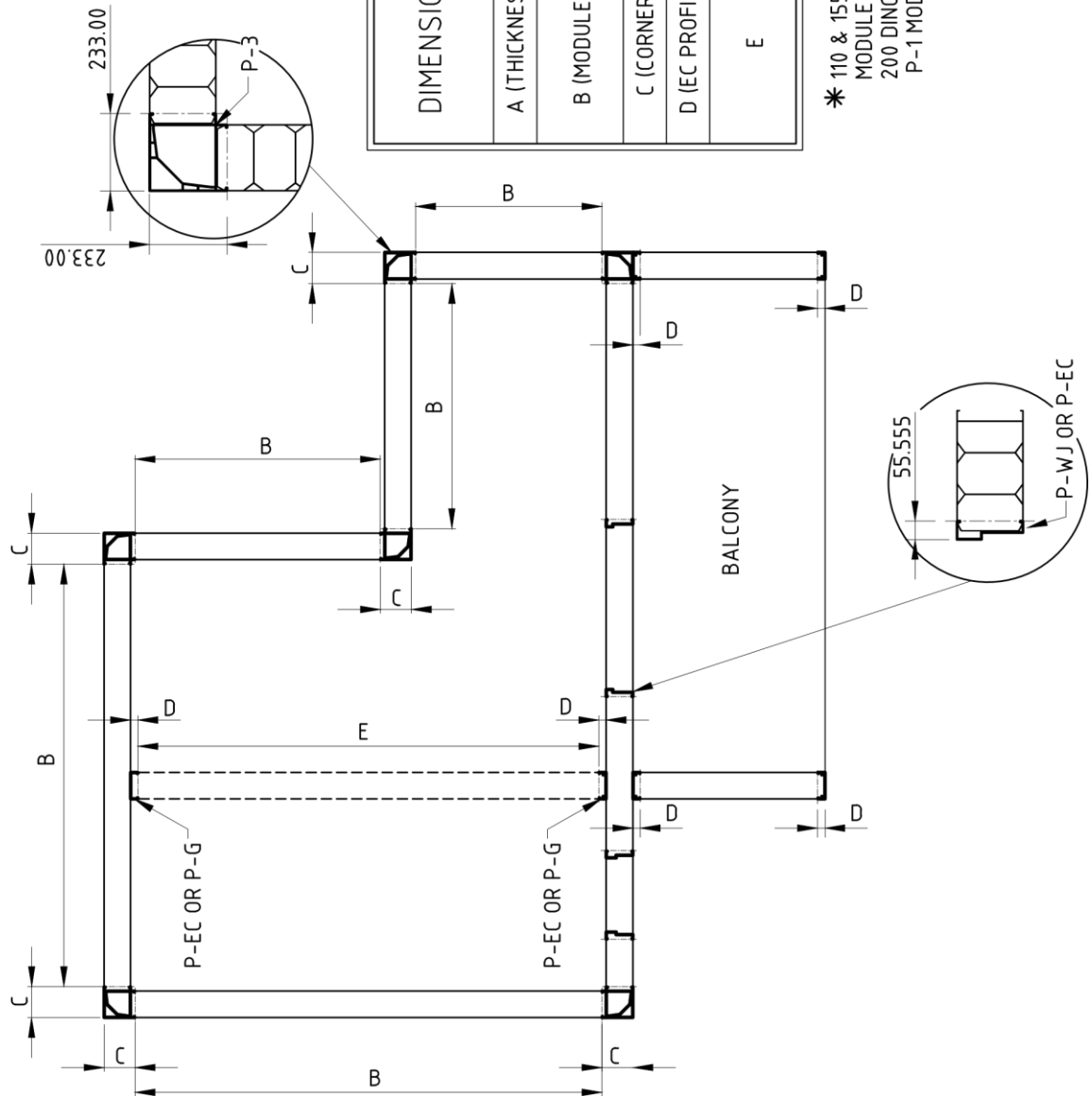

FIGURE 2



FACADE WALL - OPTION 3



DIMENSION	110 DINCEL (mm)	155 DINCEL (mm)	200 DINCEL (mm)
A (THICKNESS)	110	155	200
B (MODULES) *	@ 333.333	-	@ 55.555 OR @ 333.333
C (CORNER)	166.665	186.00	233.00
D (EC PROFILE)	55.55	75.00	55.55
E	INTERNAL WALL CAN BE ANY DIMENSION BY USING PG - GUIDE PROFILE IN LIEU OF EC PROFILE		

* 110 & 155 DINCEL ONLY AVAILABLE IN P-1 MODULES AT 333.333mm
 MODULE INCREMENTS
 200 DINCEL AVAILABLE IN P-2 MODULES AT 55.555mm AND
 P-1 MODULES 333.333mm

REFER SECTION (K) - 5 FOR
 CONSTRUCTION TOLERANCES

FIGURE 4 – ARCHITECTURAL PLAN SETOUT GUIDANCE

Architectural Detailing Incorporating Dintel-Façade Walls

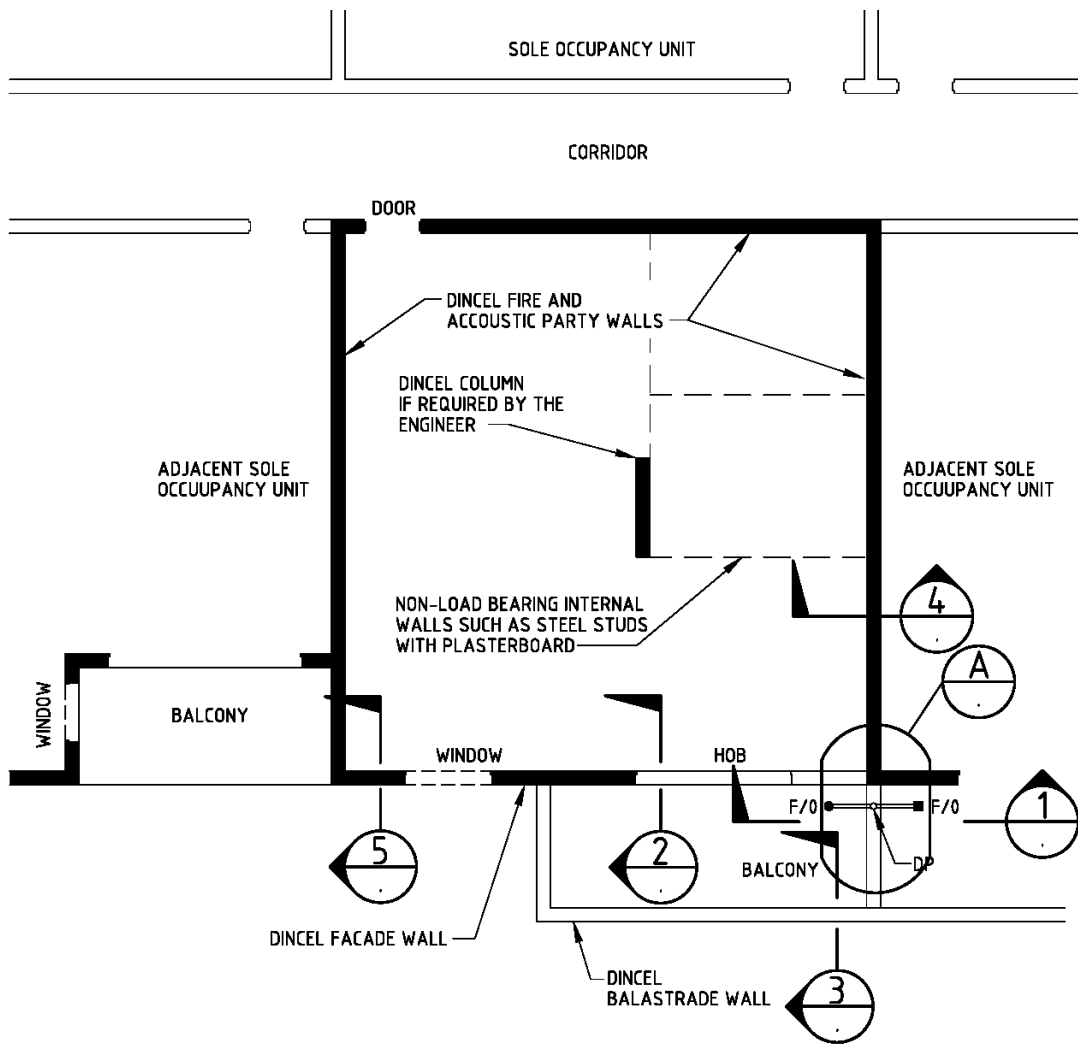

TYPICAL FLOOR PLAN FOR AN APARTMENT

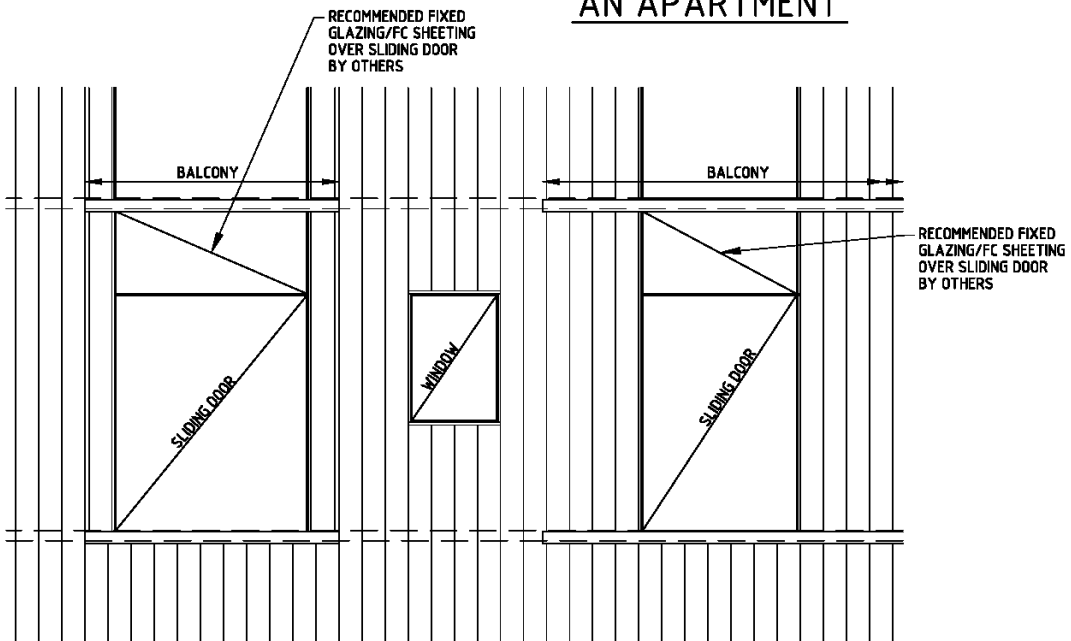

TYPICAL WINDOW - BALCONY DOOR ELEVATION
TYPICAL FACADE WALL ELEVATION

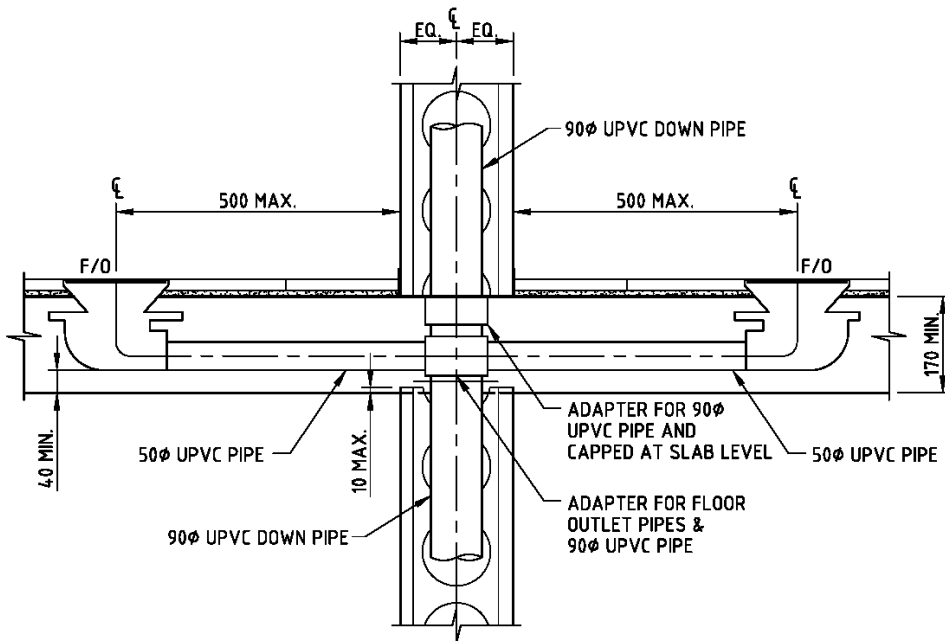

BALCONY FLOOR OUTLETS TO DOWN PIPE DETAIL

SECTION **1**
SCALE 1:10

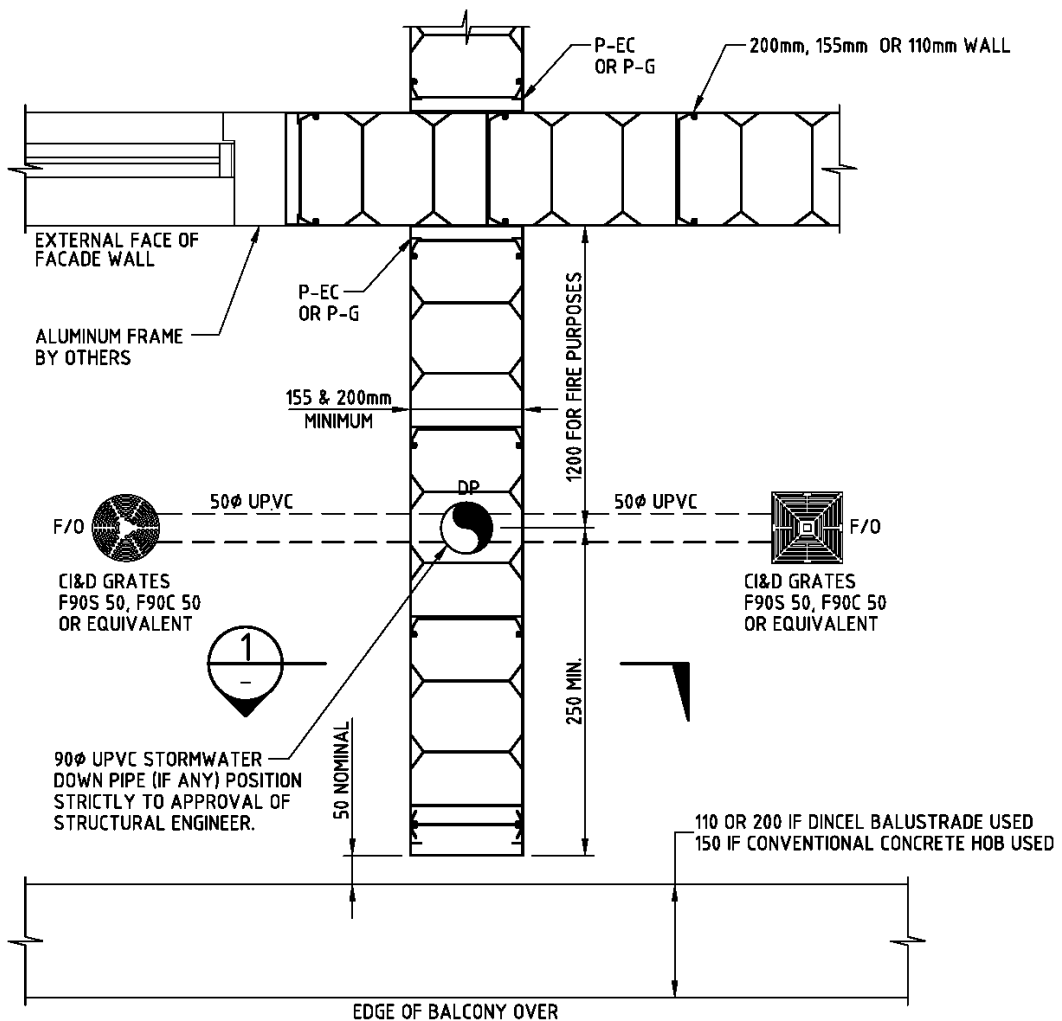

BALCONY FLOOR OUTLETS TO DOWN PIPE AT 155mm & 200mm WALL

DETAIL **A**

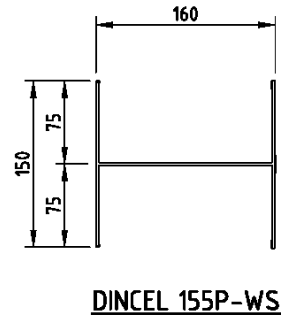
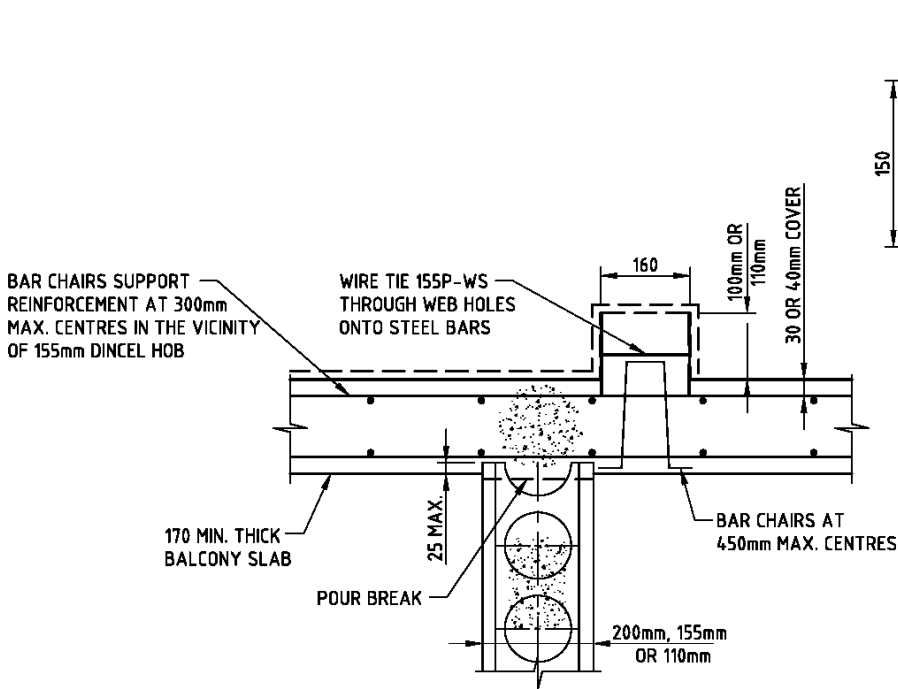

BALCONY TO EXTERNAL WALL DETAIL

SECTION 2

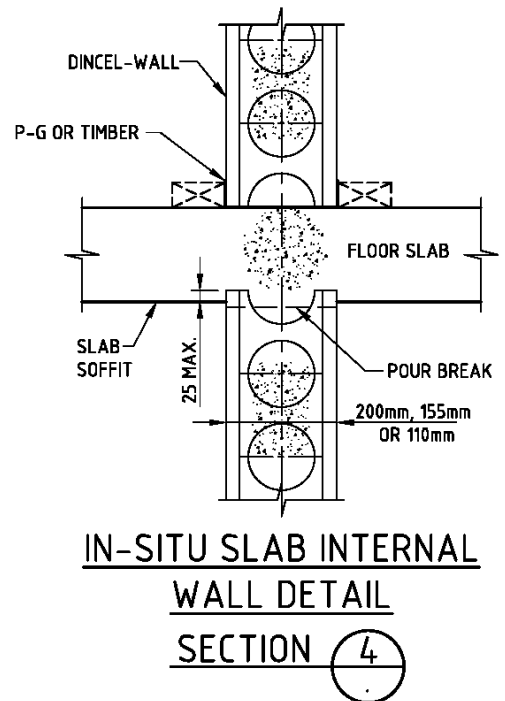
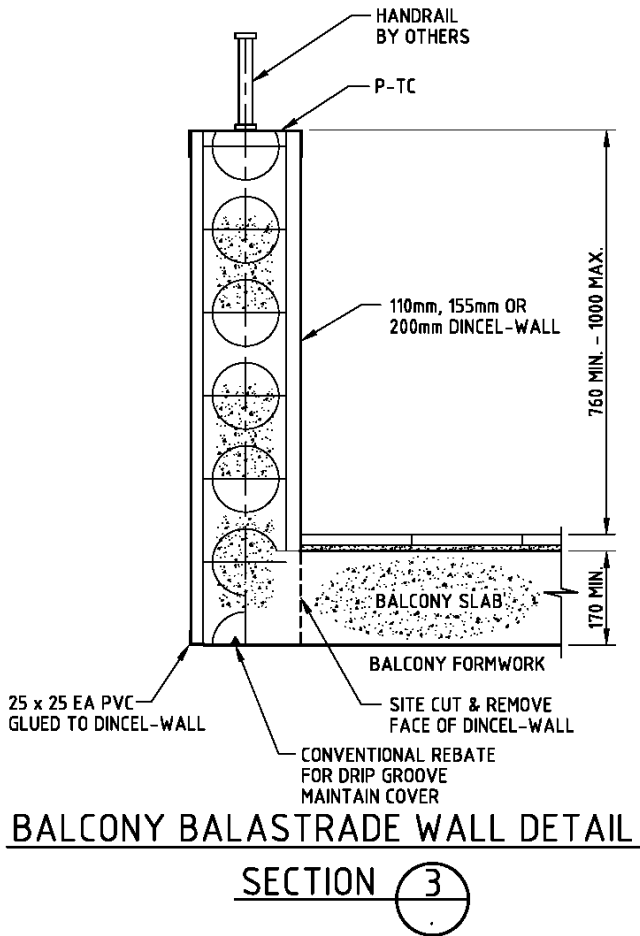

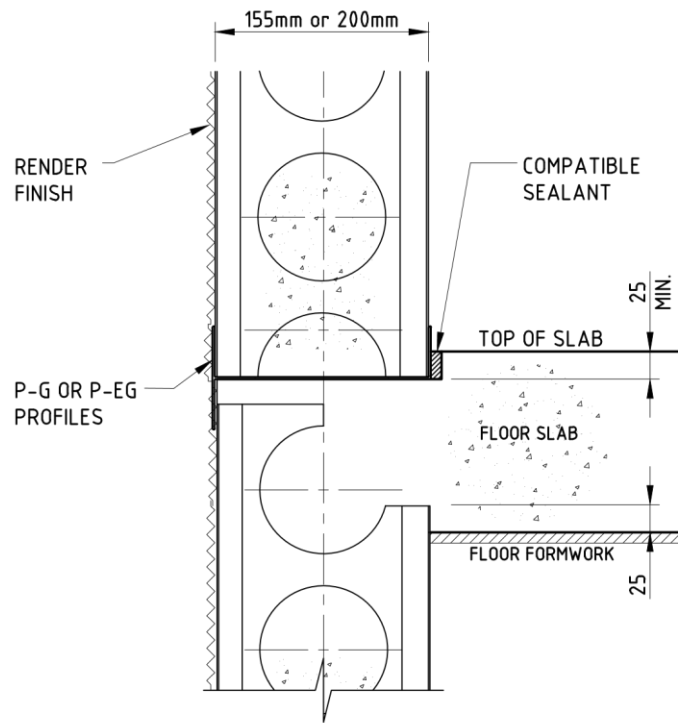
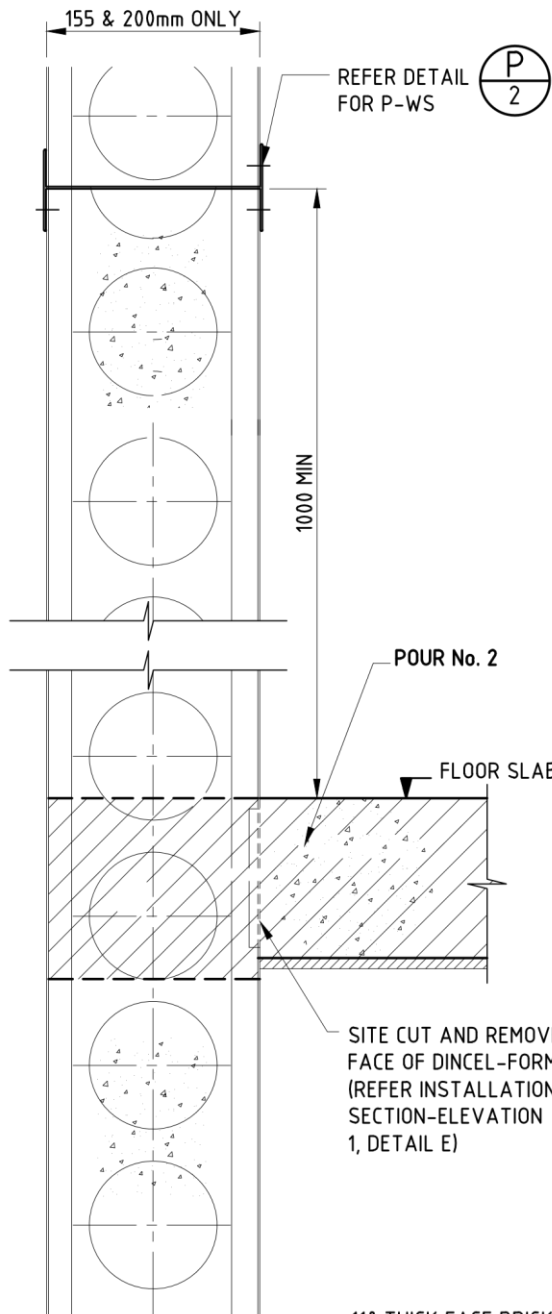

OPTIONAL DETAIL AT FACADE WALL OR SLAB EDGE

WALL EXTENDED TO WINDOW SILL-LEVEL

FACADE WALL 200mm & 155mm ONLY CONSTRUCTION WITHOUT SCAFFOLDING

110 THICK FACE BRICK OR ANY TYPE OF CLADDING MATERIAL

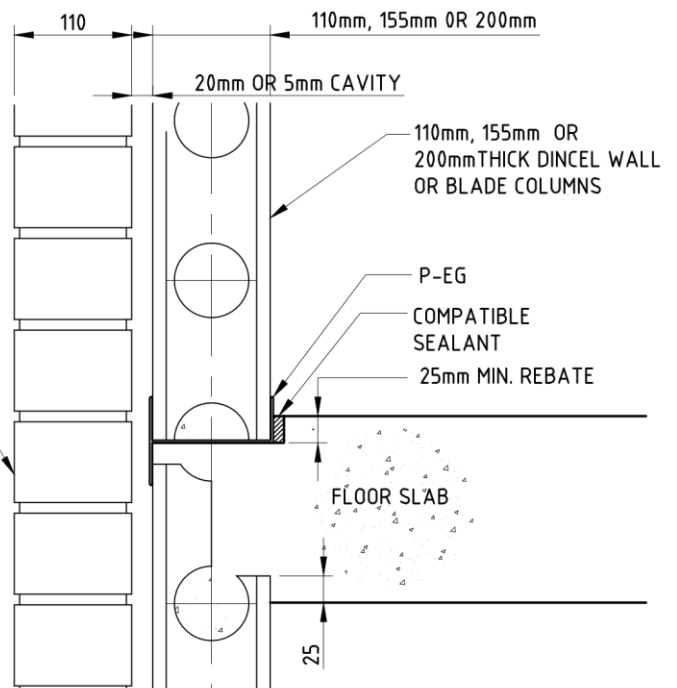

VENEER CONSTRUCTION

SECTIONS AT BUILDING FACADES

SECTION 5

INSTALLERS CUT AND REMOVE WINDOW/DOOR OPENINGS AFTER CONCRETE POURING. THIS MINIMISES WORKMANSHIP FAULTS ASSOCIATED WITH FORMWORK/PROPPING AND ACHIEVE SIGNIFICANT TIME SAVINGS.

200mm, 155mm OR 110mm WALL FIRE DOOR DETAILING

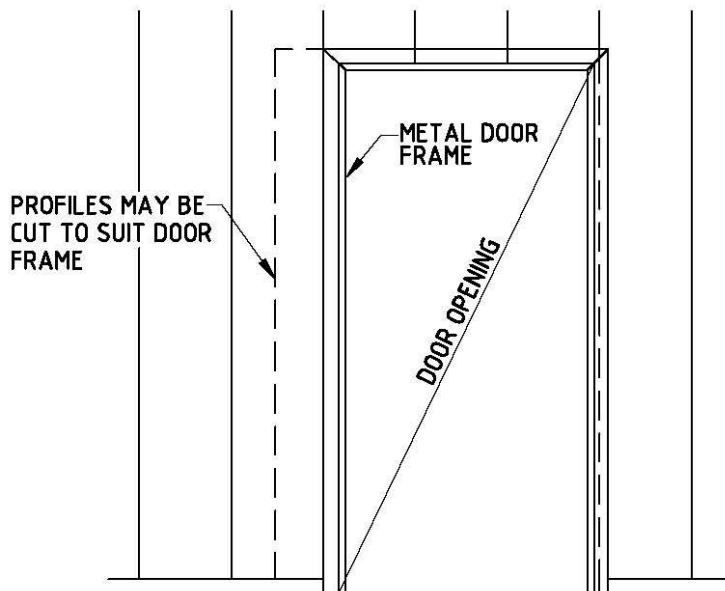

DOOR ELEVATION

METAL DOOR FRAMES CAN BE BUILT IN TO THE DINCEL-WALLS AND CONCRETED SIMULTANEOUSLY.

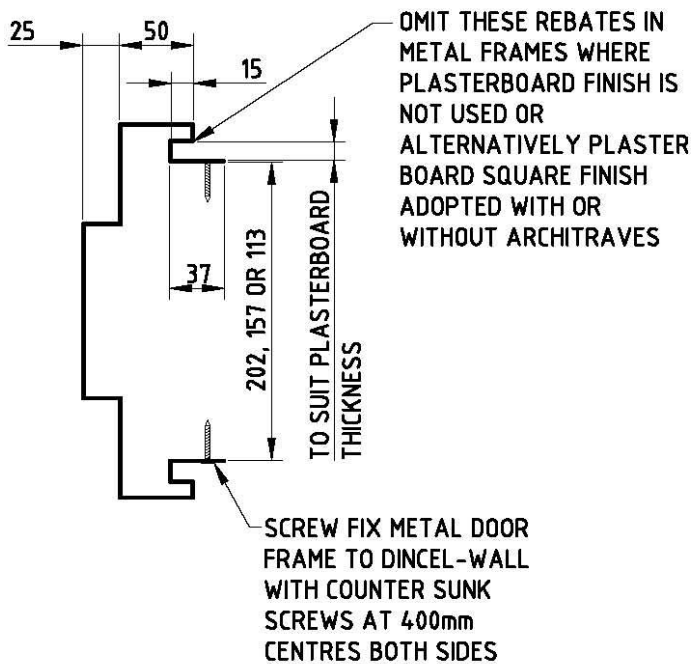

DOOR FRAME

FRAME TO BE 1.1mm OR 1.4mm STEEL

CERTIFICATION AT THE FIRE DOORS

- OBTAIN CERTIFICATES FROM RELEVANT MANUFACTURERS FOR METAL FRAMES AND DOORS FOR THE REQUIRED FIRE RESISTANCE LEVEL (FRL)
- COMPLIANCE WITH AUTHORITY REQUIREMENT TO BE ACHIEVED WHEN CONCRETE FILLS THE SPACE BEHIND METAL FRAMES AS SHOWN IN THE BELOW DETAIL

IMPORTANT NOTE:

IF METAL FRAMES (DOOR, WINDOW PENETRATIONS) ARE BUILT WITHIN THE DINCEL WALLS TO RECEIVE DIRECT CONTACT WITH WET CONCRETE OR ANY MOISTURE CONDITIONS, IT IS RECOMMENDED TO BE APPROPRIATELY PROTECTED AGAINST CORROSION (IE GALVANISING ETC.)

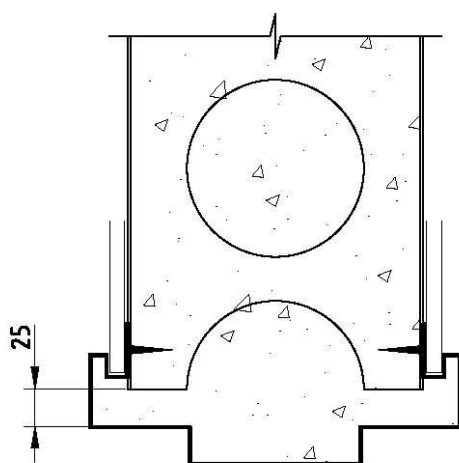

METAL DOOR HEAD AND JAMBS

WINDOW DETAILING

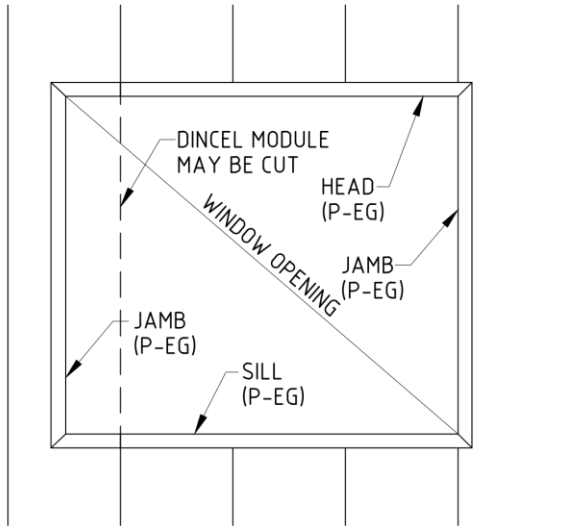

DINCEL WALL ELEVATION

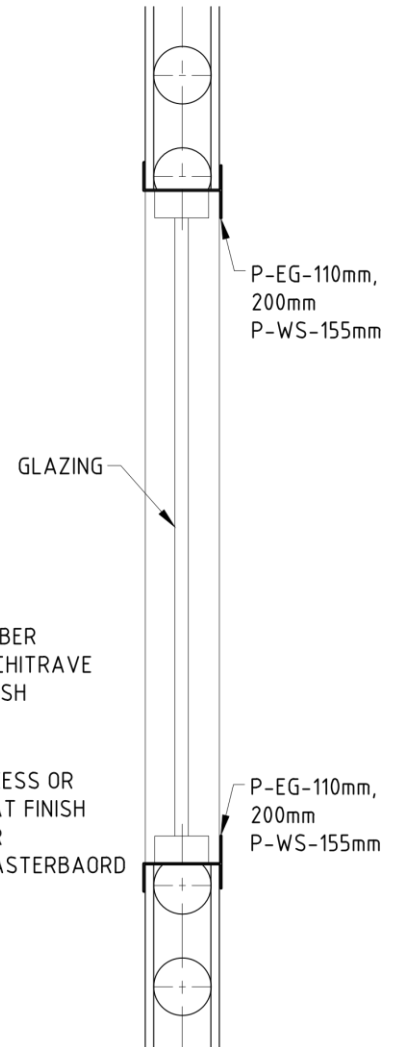

DETAIL AT HEAD & SILL

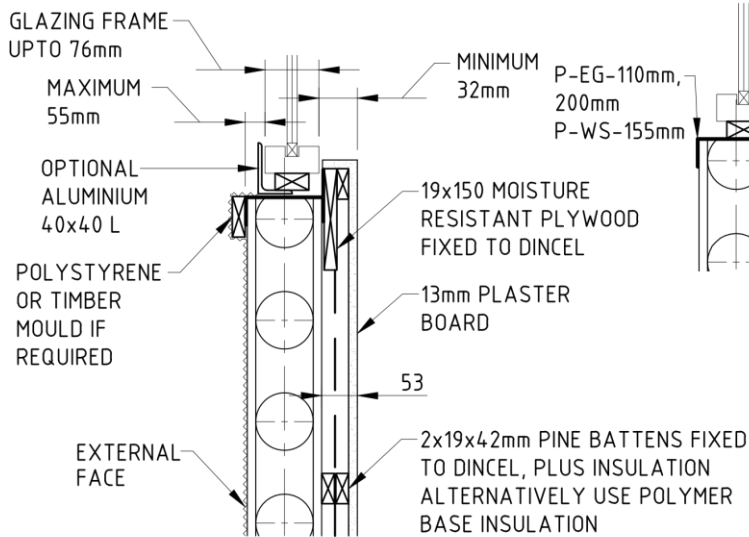

FINISHING DETAIL AT WINDOW SILL

NOTE: P-EG IS NOT AVAILABLE IN 155 DINCEL, USE P-WS BY CUTTING ONE LEG ON SITE.

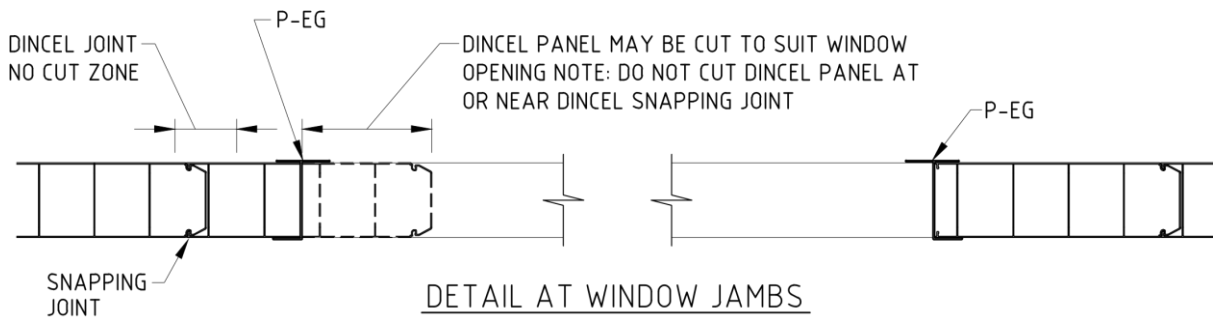

DETAIL AT WINDOW JAMBS

NOTE: IF DINCEL WALL IS CUT TO SUIT IT IS THE FORMWORKERS RESPONSIBILITY THAT END OF WALL MUST BE PROPPED TO AVOID ANY BULGING. WATERPROOFING IF REQUIRED TO BE ACHIEVED BY APPLYING APPROPRIATE WATERPROOFING MATERIAL BETWEEN P-EG AND WALL PANEL.

WINDOW/DOOR DETAILING - PROFILES PLACED HORIZONTALLY

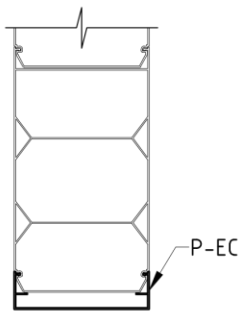
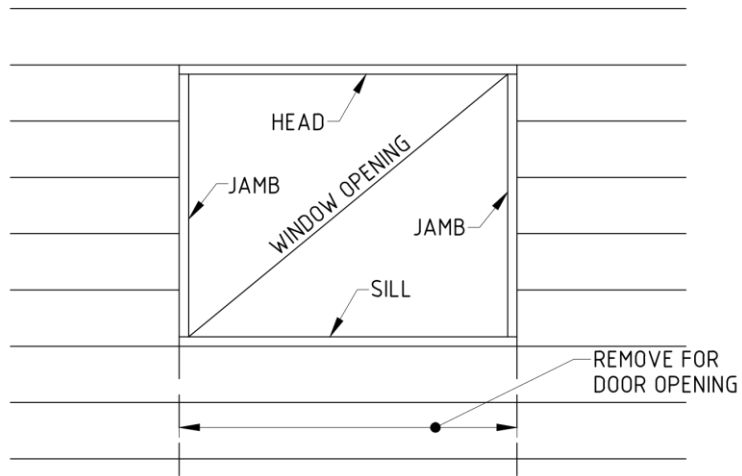

200mm HEAD DETAIL

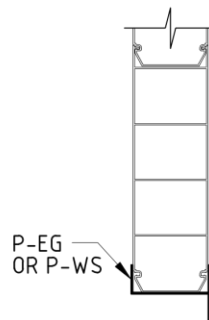

110mm OR 155mm HEAD DETAIL

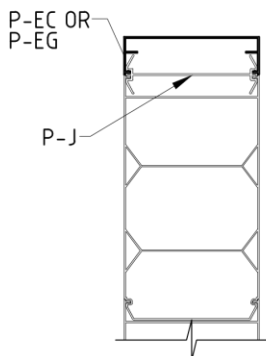
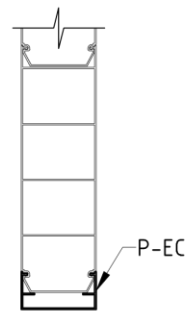

200mm SILL DETAIL

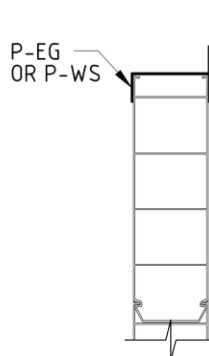

110mm OR 155mm SILL DETAIL

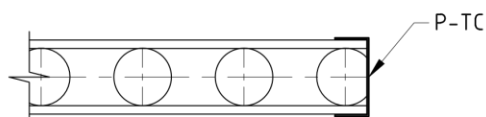
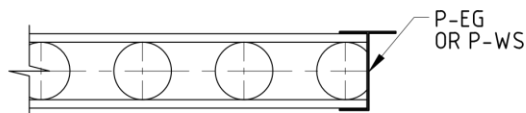
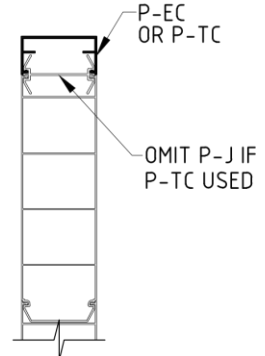

110mm, 155mm OR 200mm JAMB DETAIL

NOTE: CUT THE LEG OF 155 DINCEL P-WS TO USE AS P-EG

(F) FINISHES & JOINTS

Internal Finishes

- **Plasterboard.** To control the thickness of the glue that may be required to be attached to the plasterboard on Dincel's surface the maximum surface deviation should not exceed 4mm over a 1.8m long straight edge.
- **Render/White-set.**
- **Exposed or Paint** (i.e. panel joints visible).

External Finishes – Exposed to Direct Sunlight

- **Paint** (i.e. panel joints visible). No joint in Dincel base wall is required.
- **Brick, stone, cladding, aluminium panelised forms.** No joint in Dincel base wall is required.
- **External face with foam board plus suitable render.** Recommended finishing, no joint in the Dincel base wall is required. Refer Dincel's website document titled "**FINISHES**" for details.
- **100% Acrylic Render** directly on the Dincel Panels (cement or cement modified renders are not suitable).

Important Note: If and when Dincel Wall is finished with direct render application on Dincel, the following are important to implement.

Dincel is not a render manufacturer or render applicator.

- Obtain render manufacturer's and render applicator's warranty that the rendering product offered to use on Dincel is appropriate. Refer Dincel's website document titled "**FINISHES**" for further guidance.
- All renders, particularly dark colours, require joints; obtain advice on the joint location and spacing from the render manufacturers and building professionals.

(G) TERMITE TREATMENT

Termite treatment is not required with **DINCEL®-WALL**. Refer Dincel website for comprehensive information.

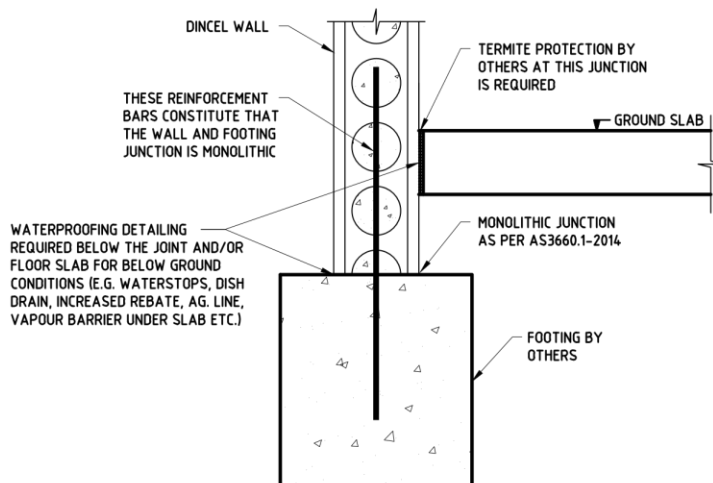
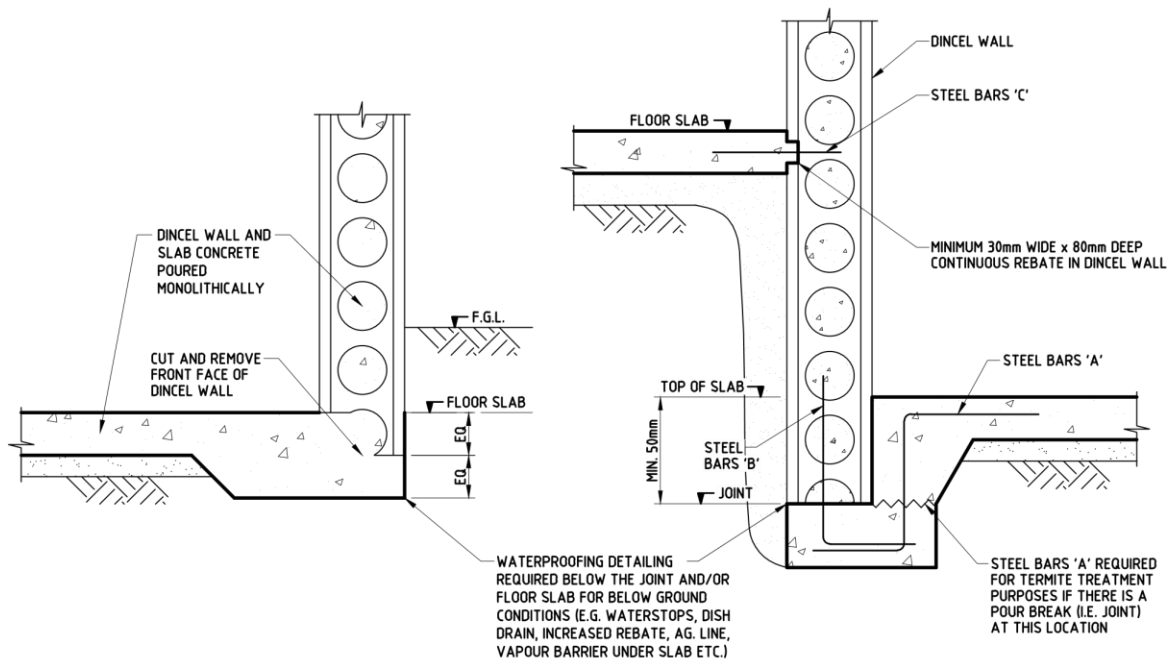

AS 3660.1 COMPLIANT DETAIL TO AVOID TERMITE TREATMENT AT SLAB EDGES AND RETAINING WALLS

NOTE: REFER DESIGN ENGINEER FOR BARS 'A', 'B', 'C',
FOOTING AND SLAB REINFORCEMENT SPECIFICATION

(H) SERVICES

(i) **Electrical Cablings and Switches**

The 60mm x 25mm built in raceways of the 200mm Dincel panels can accommodate electrical cablings and a switch box with walls having plasterboard wall finish. In-built service channels are only available for 200mm thick Dincel-Walls.

Alternatively, provide cavity by the provision of battens on **DINCEL®-WALL** to accommodate electrical cabling if 110mm walls are used. The cables can be placed within the concrete walls if suitable to the builder and building designers.

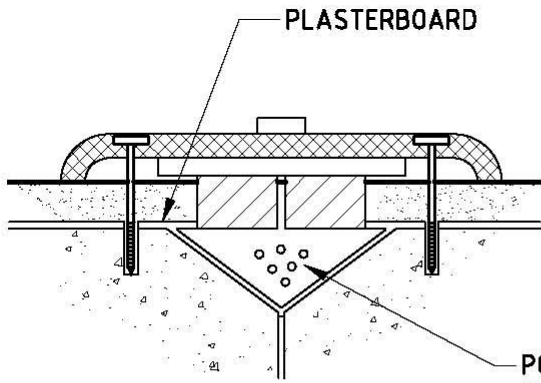

TYPICAL G.P.O. PLAN VIEW

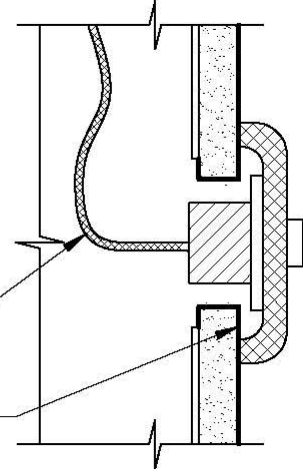

TYPICAL SECTIONAL VIEW

(ii) Plumbing Services

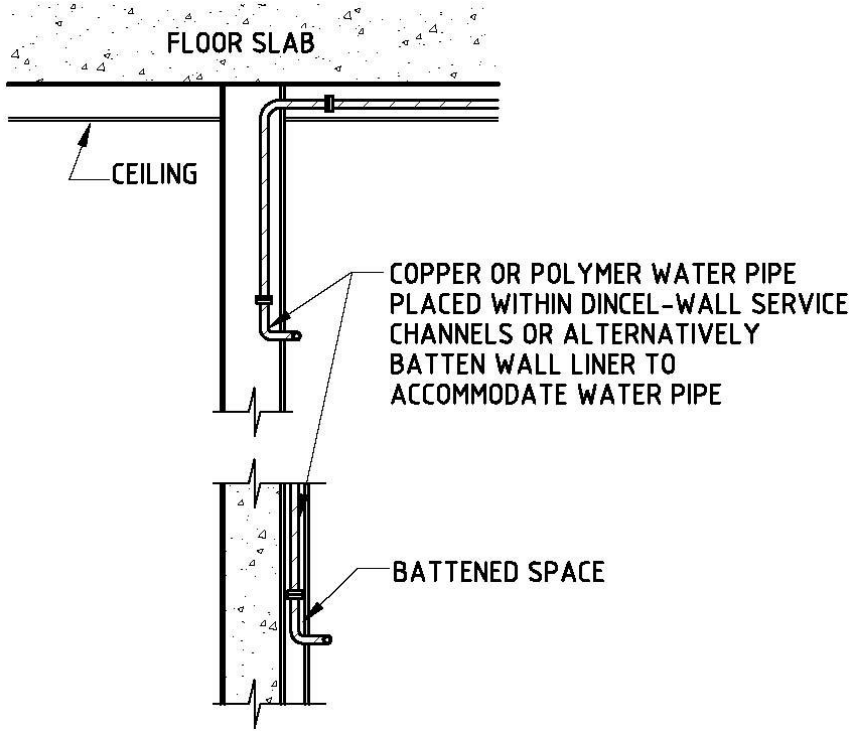

TYPICAL WALL SECTION FOR ACCOMMODATION OF WATER PIPES

(iii) Service Duct Penetrations

Typical section and elevations for ventilation / air conditioning duct penetrations above false ceilings return air grill penetration below ceiling lines.

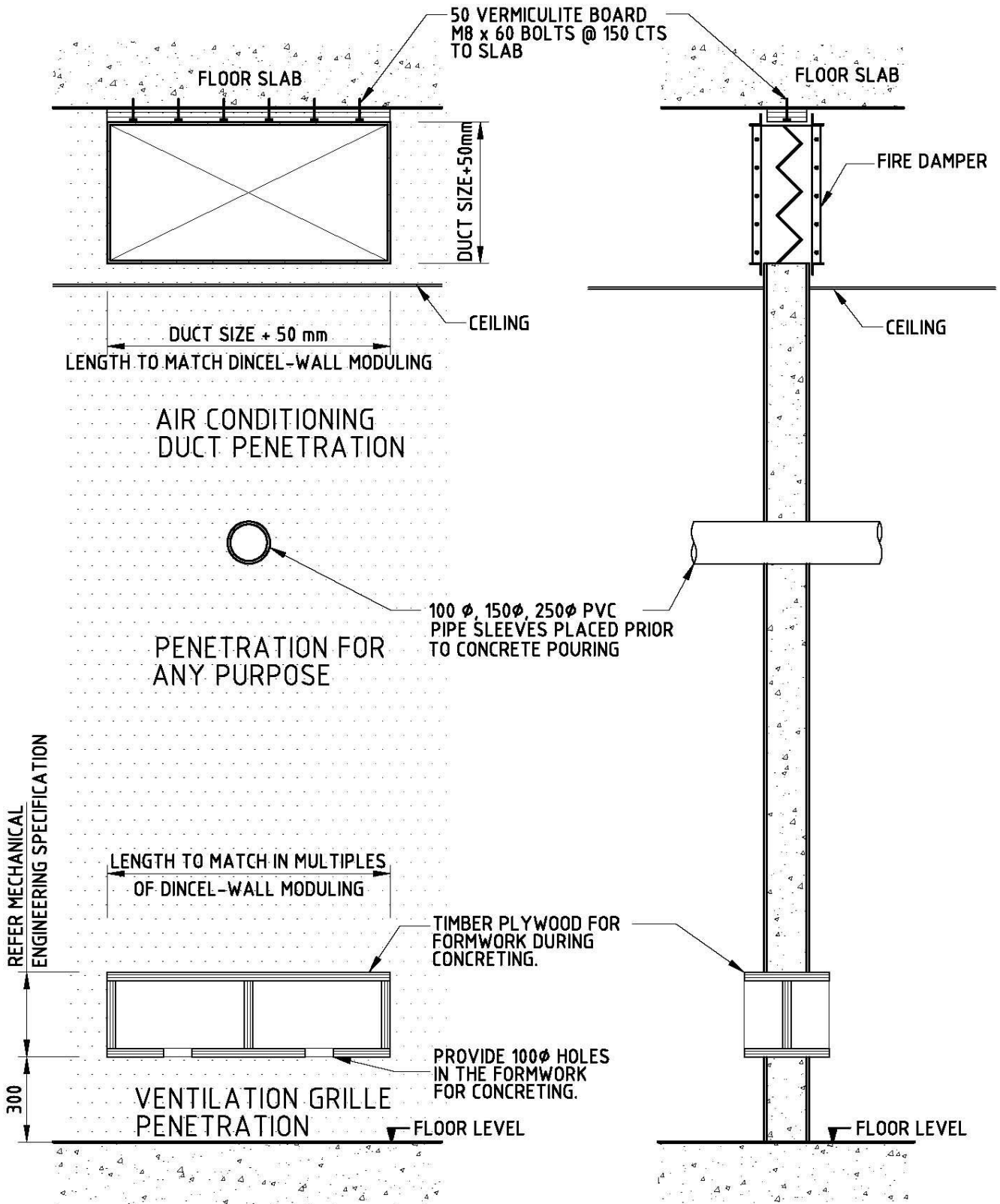

ELEVATION

SECTION

WALL PENETRATION DETAILS

(I) FIRE SEALANT/COLLAR USE AT ABUTTING FIRE WALLS

The following details are a summary from AS 1530.4 Test for Fire Sealants. Contact Dincel for a copy of the Fire Test Report to avoid misuse.

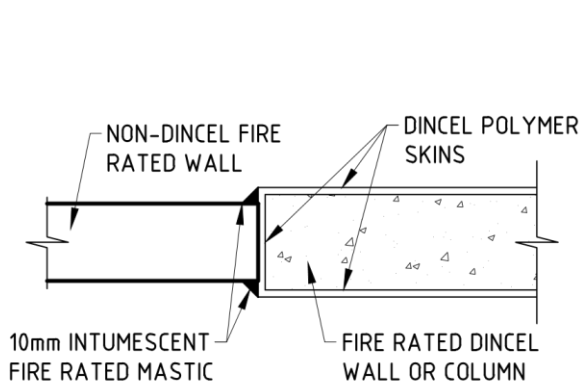

WALL JUNCTION-PLAN

PROVIDE BACKER ROD OR MINERAL WOOL WHERE THE GAP IS GREATER THAN 10mm

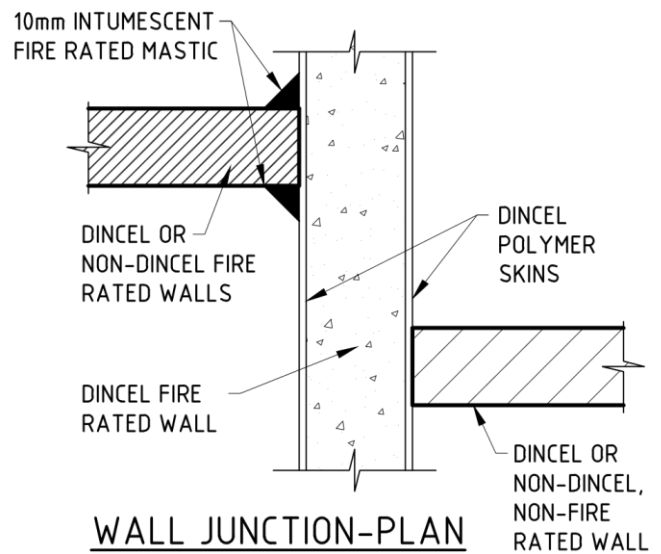

WALL JUNCTION-PLAN

PROVIDE BACKER ROD OR MINERAL WOOL WHERE THE GAP IS GREATER THAN 10mm

FIRE RATED WALLS ABUTTING HARD AGAINST TO EACH OTHER-PLAN

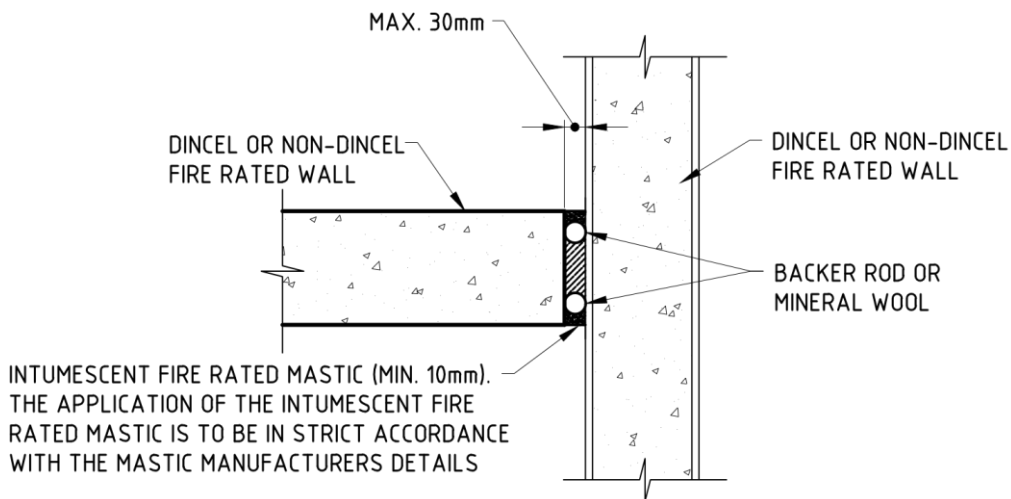

FIRE RATED SEALANT APPLICATION WHERE THE GAP IS GREATER THAN 10mm AT ABUTTING WALLS

FIRE SEALANT USE AT DINCEL WALL

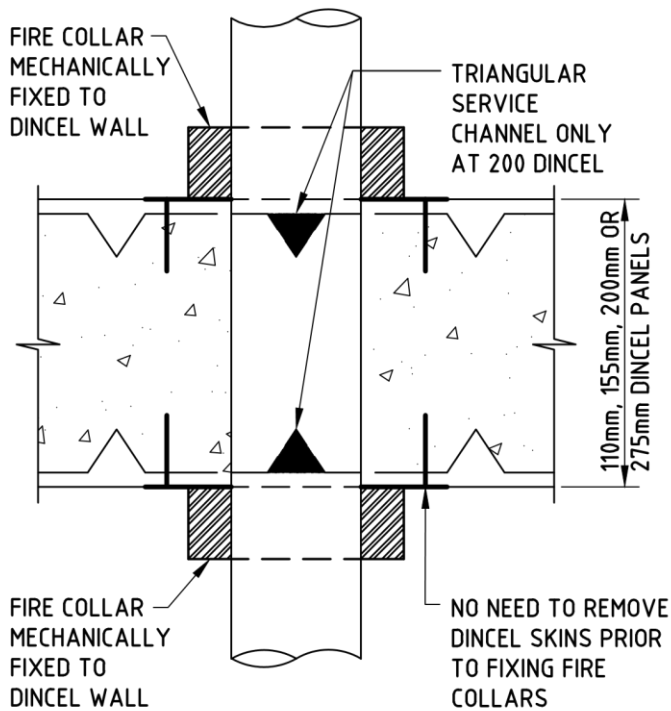
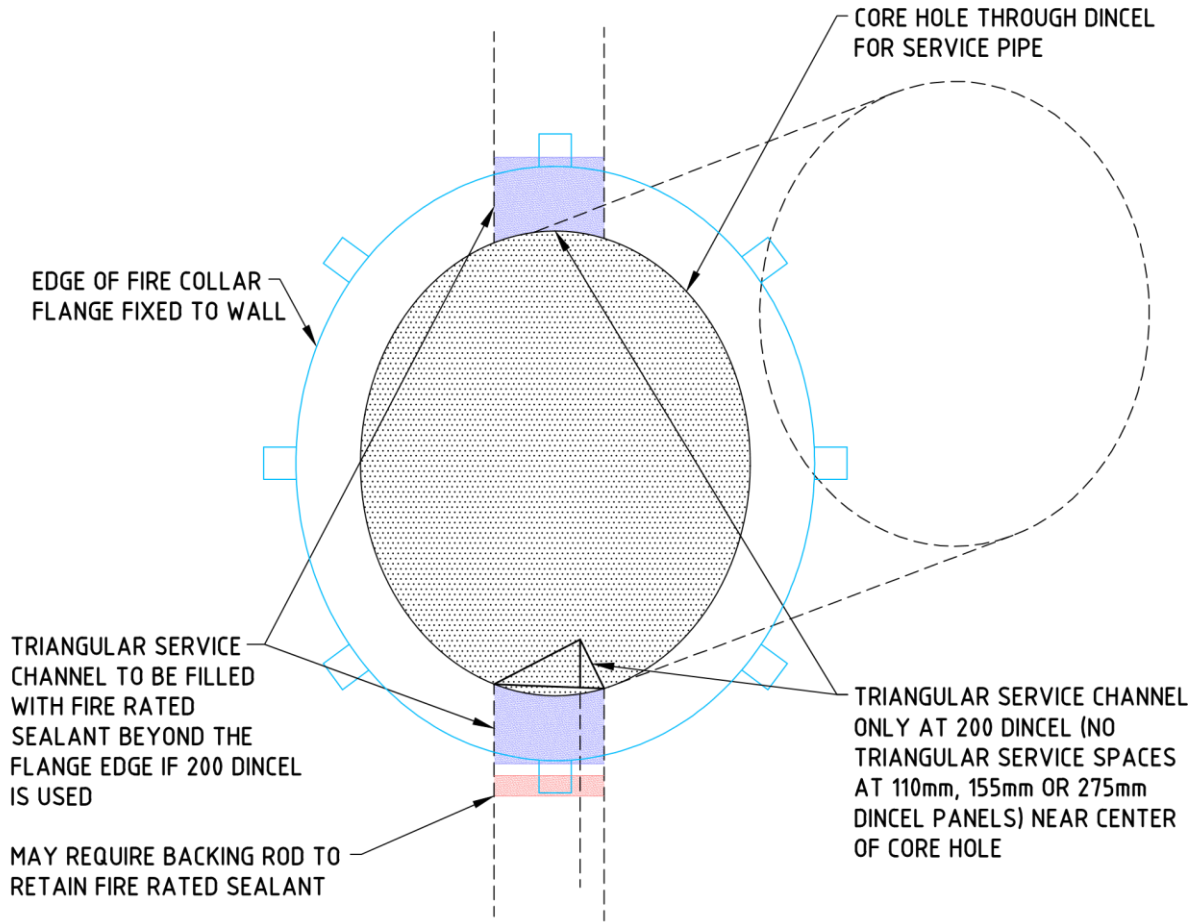

SECTION

FIRE COLLAR INSTALLATION AT 200 DINCEL

NOTE: OTHER DINCEL PRODUCTS DO NOT CONSIST TRIANGULAR SERVICE SPACERS SHOWN ABOVE)



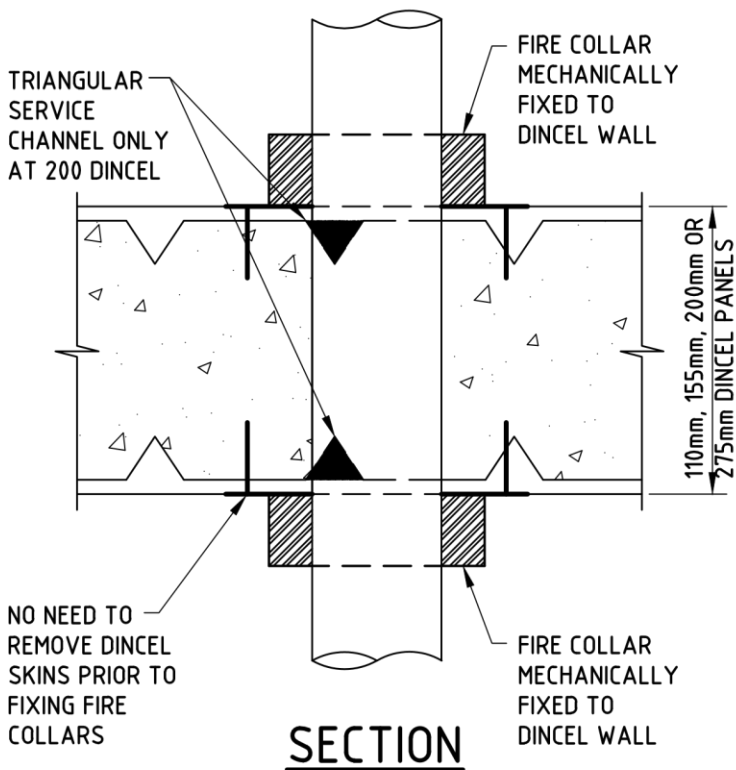
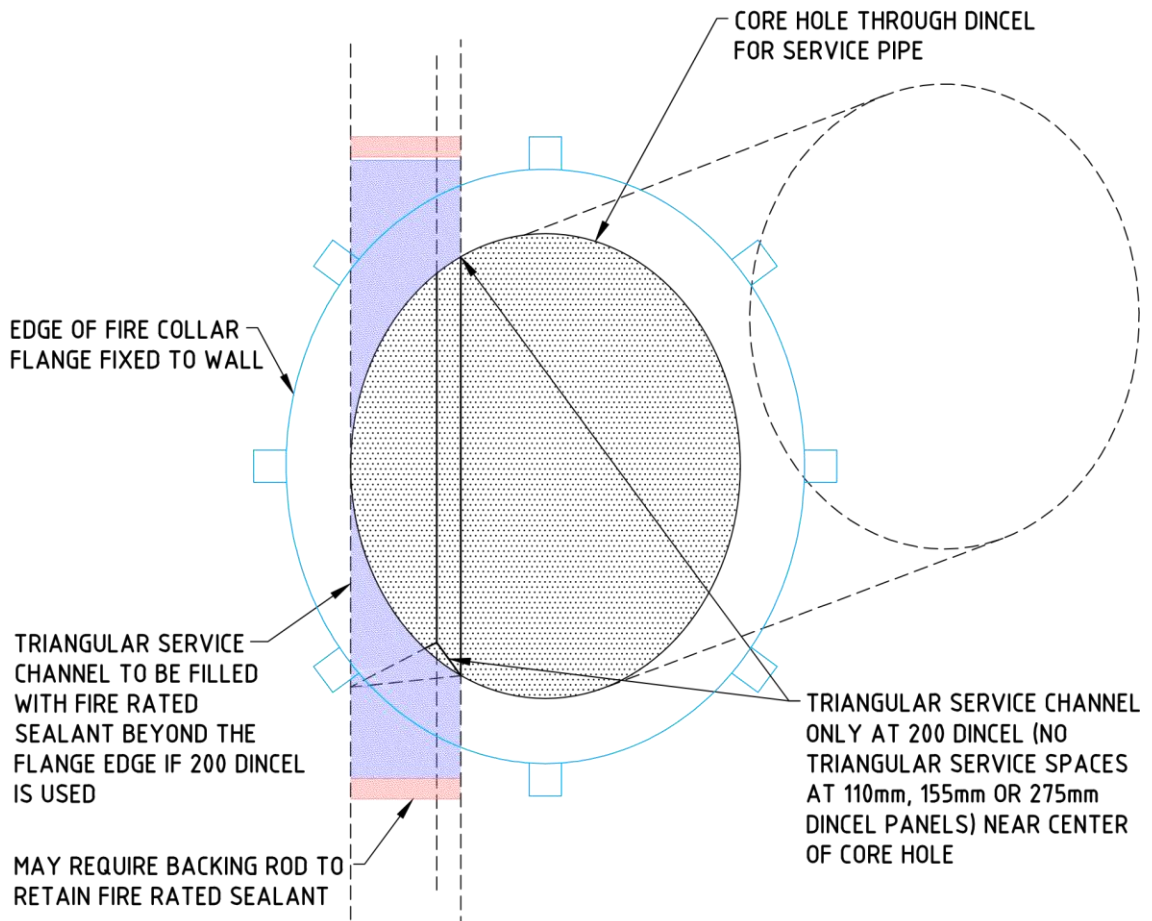

FIRE COLLAR INSTALLATION AT 200 DINCEL

NOTE: OTHER DINCEL PRODUCTS DO NOT CONSIST TRIANGULAR SERVICE SPACERS SHOWN ABOVE)

INSTALLATION AND CONCRETING – DINCEL[®] - WALL

(J) Installer’s Dincel Product Acceptance Criteria

Refer Page 1 – “Disclaimer”, refer Page 4, Item No: (C) – “The Use of this Manual”.

The Dincel permanent polymer formwork like conventional plywood formwork also has its limitations.

When Dincel forms are filled with concrete, under concrete pressure, can demonstrate a rippling feature (i.e. vertical ridges) at where the panels join each other. The reason for this is that the joint between the panels can move under concrete pressure. The rippling feature of about 2mm or maximum 3mm shall be treated as an acceptable finish for walls up to 3m to 4m in height. The degree of rippling will change depending on how high the concrete fill is and how the concrete is poured. Care during concreting can eliminate the rippling feature.

Dincel recommends maximum 5m height concrete pour on any day pour – refer following Item No: K9. Depending on the skills of the installer, Dincel’s surface finish should represent Class 2 to Class 4 as per Table 3.4.2, AS3610 – Formwork Code if the wall height is limited to maximum 5m. **Refer Dincel’s website document titled “Finishes” for photos representing acceptable finishes.**

For bulging to occur the web-links of the Dincel panels must be damaged. It is the responsibility of the installer to fix bulged or damaged panels, if any were to occur. The installer must accept that the installation of Dincel walls might have the possibility of bulging/damages occurring for a number of reasons as per Item No: K6. This possibility of bulging/damages with Dincel forms that might occur shall be treated no differently than the bulging/blowouts that commonly occur with conventional concrete walls with removable formwork.

As a manufacturer Dincel Construction System Pty Ltd shall not take any responsibility for installation matters, including waterproofing and bulging. Plumbing, straightness, squareness, achieving flush walls, class of finishing, etc. that may occur at the construction site after acceptance of the product (refer Dincel’s Terms and Conditions of Sale, Clause 6).

Dincel Construction System highly recommends that Dincel users should require the acceptance of the above from their installers by signing below.

Project Name:.....

Date:

Name of Installer:.....

Signature:.....

Company Name:.....

To ensure successful **DINCEL®-WALL** projects, it is critical that installers follow the recommended practices below. Please read the following pages carefully – these tips **will** make a difference!

Particularly on your first **DINCEL®-WALL** pour, **allow extra time** to complete the details and double-check that the walls are Plumb, Straight, Square, and Level and properly supported. Good preparation will always result in a higher quality job and save time in the long run.

(K) RECOMMENDATION FOR INSTALLATION, CONCRETE MIX DESIGN AND PLACEMENT

1. Safety Comes First

The installer must adhere to all safety issues normally required with formworking and concreting trades. Where **DINCEL®-WALL** module is required to be cut in the site, all installers must wear appropriate dust-proof respirators and protective eyewear. Appropriate cutting devices consisting of grinders with steel blades or carpenter's circular saw shall be used. Refer Dincel website for "Dincel Solution for Construction Safety".

2. Do not attempt installation during high wind conditions.

3. If Unsure – Ask The Question

It is the responsibility of the installer to read and understand this manual thoroughly. If you are not sure, ask the question first before you do anything.

4. Shop Drawings

The shop drawings are rather essential for façade walls incorporating window/door openings. However, shop drawings are not necessarily required for straight walls such as basements and party walls.

5. Installation Methodologies and Tolerances

The installers of **DINCEL®-WALL** need to be supervised by a person who has at least conventional formworking, carpentry or site foreman qualifications to adhere safe construction practices. These include the requirements of the applicable local authority's Occupational Health and Safety rules, building code of practice for formworking and concrete steel placement. The most important issues for installation are to secure forms against loadings such as winds, accidental impact and concrete pouring.

Refer to Items 17, 18 and 19 for installation methodologies and the Dincel document titled "Dincel Solution for Construction Safety" which is available on the Dincel website.

Polymer forms may be subjected to shrinkage and temperature shortening/elongation depending on the length, height and daily temperature. Installers should allow nominal 10mm movement for 15m or 20mm for 30m long walls for each 10°C temperature variation above and below 20°C.

In addition to temperature movement, a construction tolerance of -1mm needs to be allowed at each main profile. It is therefore recommended that the adoption of 333mm – 1mm = 332mm module dimension be used for the dimensional set out of the wall under consideration.

6. To Avoid Bulging of the Dincel Forms

For bulging to occur the web links of the Dincel panels must be damaged because of the following reasons: (Also refer to the Manual titled "**Guidance and Tips for a Smooth Handling and Installation**").

Avoidance of the following will ensure good results:

Upon delivery: Dincel panels are packed in timber crates and delivered to the construction site.

- Proper wide flat lifting slings (not chains or round ropes) should be used to lift Dincel packs if cranes are used at the construction site. Do not lift more than two (2) Dincel delivery packs at a time unless lifting bars are used. This will prevent panel webs being squashed and possibly damaged.
- The crane operator shall ensure that the packs are softly placed on the site's storage area without dropping the packs from height whilst transported by a crane.

Product Storage:

When daily temperatures are constantly over 30°C, the product should be kept under cover without restriction of air flow around the product.

The product is delivered to the construction site in packs with timber crates around them. Do not stack more than 3 packs on top of each other. It is the customer's/installer's responsibility to store the packs on a clean flat area with timber sleepers placed at 1,000mm (maximum) centres. The product will have a tendency to deform if they are stored with uneven and inappropriate support. The stored product may collect dust over a period of time in a construction site's condition (refer Item No: 23).

During installation:

Issues that must be considered during installation:

- Check that no panel web-link is damaged.
- Wash panel joints if there is dust/dirt accumulation.
- All panel web-holes must align with each other for the free flow of concrete.
- P-G and P-EG profiles should only be used where the surface is flush and free of irregularities.
- All steps in footings and walls must be in 150mm increment to match the web-holes of adjacent panels for the free-flow of concrete.
- Use slumps in accordance with the following Item No: 9 (Table 1).
- Use vibrators in accordance with the following Item No: 11.
- All wall ends, corners and openings are to be secured – refer to the following Item Nos: 15 and 16.
- The following Item Nos: 8, 9, 10 and 11 are for concrete pouring.
- The following details are recommended to be adopted.

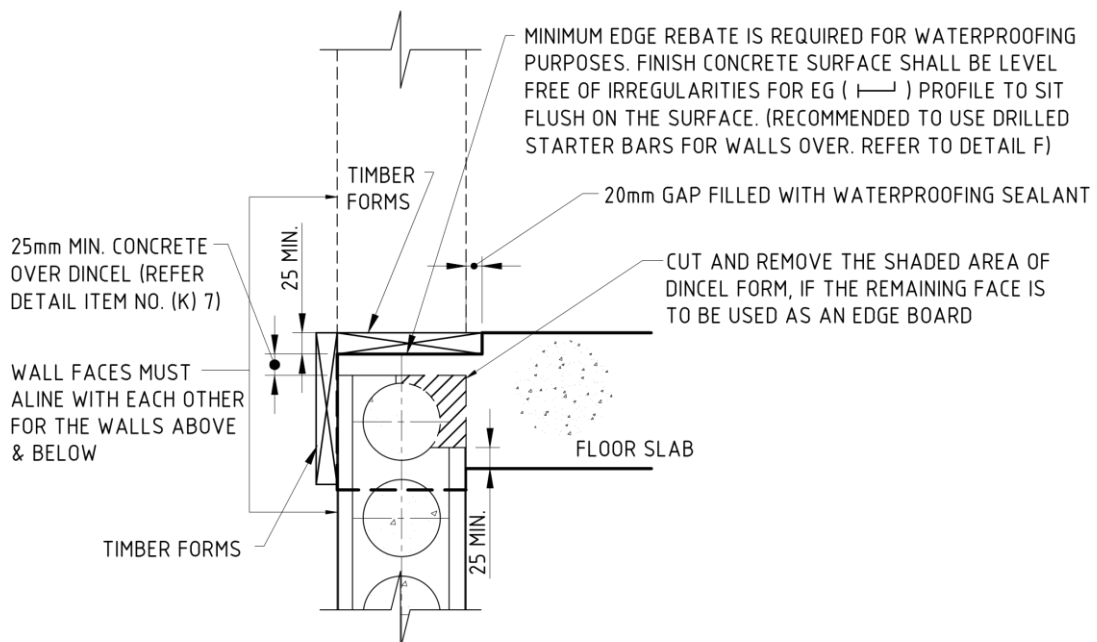

FACADE WALL SLAB EDGE DETAIL

REFER TO FOLLOWING DETAILS O, P & S FOR ABOVE GROUND AND DETAIL C FOR BELOW/ON-GROUND CONDITIONS FOR THE USE OF P-G, P-EG PROFILES

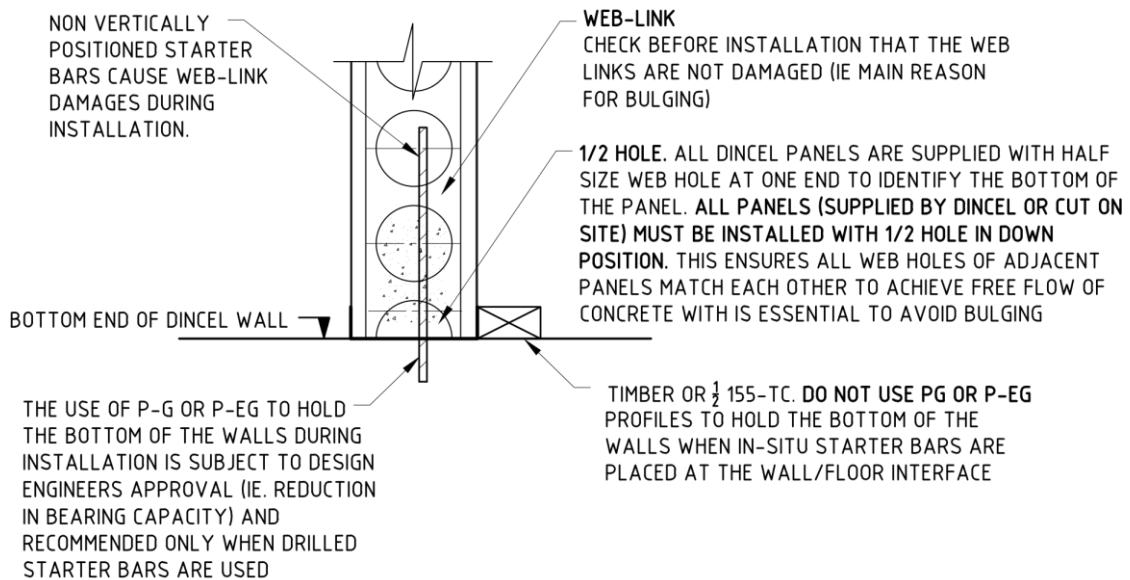

DETAIL AT BOTTOM OF DINCEL WALL

7. Construction Provision For Service Channels and Snap-On Joints

The 25 x 60 service channels of the 200mm Dincel wall and snap-on joints of Dincel-Wall may receive concrete, concrete slurry, wash-down water from cleaning the formed decks or rain water during construction or even after construction if the top of Dincel-Walls are not covered. The cover can be achieved by the details below by having minimum 25mm concrete or by providing the Profile – TC or by metal capping or stone capping.

Avoid Rain/Wash-Down Water In Service Channels and Snap-On Joints

The 200mm Dincel profiles are manufactured with weep holes at the service channels at the bottom of the walls to drain the water prior to the final finishes if the top of the walls are not protected for ingress of water during or after construction. Refer to the Dincel website for the document titled “Dincel Solution for Render Cracking”. All Dincel Walls’ top ends must be covered when the product receives paint/render applications.

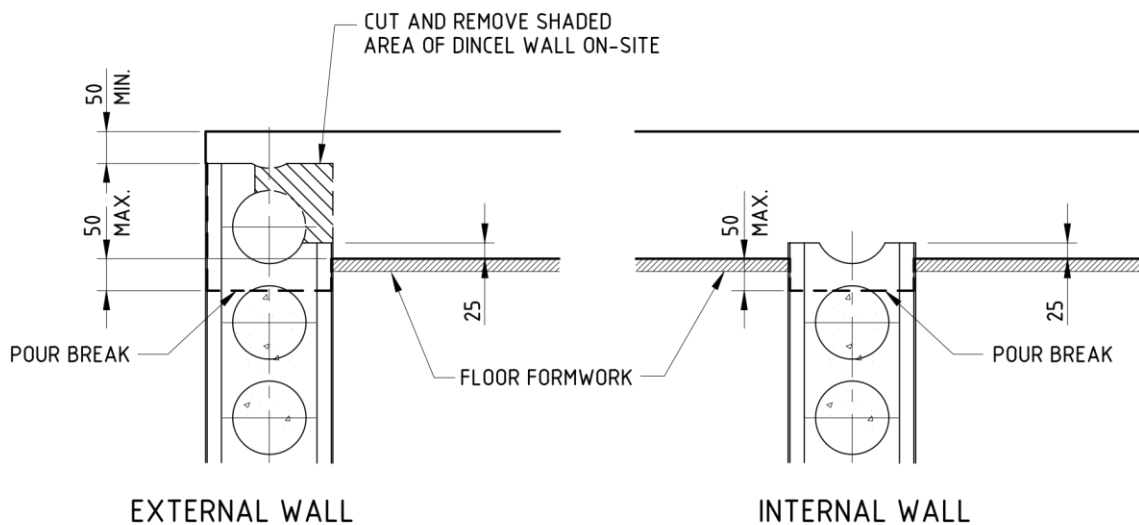

DETAILS TO AVOID WATER IN SERVICE CHANNELS AND PANEL JOINTS

8. Concrete Pouring Temperatures

Do not pour concrete when the daily temperature is over +35°C or under +5°C.

9. Concrete Placement

The placement of concrete can cause the formwork to move laterally if large variations in the concrete height are created. The surface movement may not be important where Dincel is cladded with plasterboard and façade wall claddings. However, the aesthetics will be an important issue where Dincel is not covered, such as basement or rendered/painted façade/internal walls. Refer Item (F) – “Finishes” of this manual for more information.

The following table is recommended to be used as a guide to achieve a reasonable surface appearance.

TABLE 1 – FOR VERTICALLY INSTALLED DINCEL WALL FOR CONCRETE POURING PURPOSES ONLY							
Wall Thickness	Use	Wall Height (metres)	1 st Pour	Minimum Wait Time (Hour)	2 nd Pour	Minimum Wait Time (Hour)	3 rd Pour
110mm OR 155mm OR 200mm Concrete Type A	Above Ground or Walls Not Subject to Earth/Water Pressure	1.8m	1.8m	-	-	-	-
		3.0m	1.2m	0.5	1.8m	-	-
		4.0m	1.8m	0.5	2.2m	-	-
		5.0m	1.2m	0.5	1.8m	1.0	2.0m
155mm Concrete Type (refer Table)	Basement Perimeter Retaining Wall NOT Subject to Permanent Water Table	2.8m	2.8m A	-	-		
200mm Concrete Type (refer table)	Basement Perimeter Retaining Wall NOT Subject to Permanent Water Table	2.8m	0.6m B	0.5	2.2m A		
		3.8m	0.9m B	1.5	2.9m A		
200mm Concrete Type B	Liquid Storage Tanks	2.1m	2.1m B	-	-		
		2.8m	0.9m B	1.0	1.9m B		

Concrete Type A: 10mm Aggregate; Minimum 140mm Slump; Maximum 180mm Slump
Concrete Type B: 10mm Aggregate, Minimum 180mm Slump; Maximum 230mm Slump

- **Where walls are placed horizontally** (i.e. factory warehouse type of walls), the recommended concrete placement is maximum 1.0m vertical lifts.
- Continue concrete pouring only after the concrete has achieved some initial setting. The concrete shall be placed in layers that are approximately horizontal.
- The rate of concrete placing shall be such that each successive pour lift can be vibrated into the previous lift for proper bonding where concrete is to be placed in two or more stages, and where a monolithic structure is required.

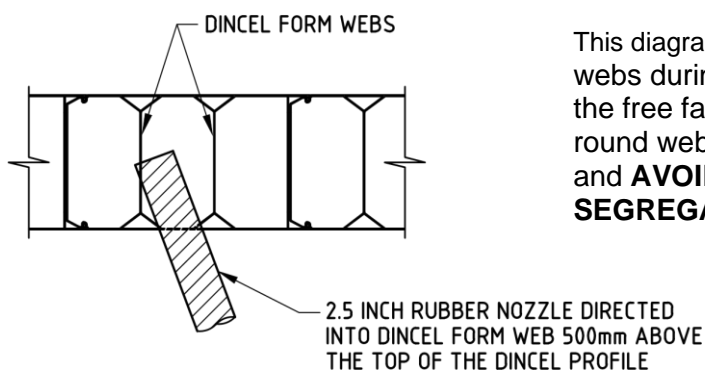

This diagram shows a pump nozzle directed to Dincel's webs during a concrete pour. This practice slows the free fall of the concrete by the presence of the round web holes (i.e. works as an elephant trunk) and **AVOIDS THE POSSIBILITY OF CONCRETE SEGREGATION.**

- Further to the above it is recommended that:
 - **Fill the window sill first, slow down the flow rate of concrete against window/door side openings and wall ends.**
 - It is preferred to finish the concreting at the top formwork by using 25mm pocket vibrators to achieve even surfaces. **Never leave finished concrete surface uneven at the top of the forms. This will be particularly critical to have compacted and even surfaces under precast/metal decks. Following compaction at the top of the walls, screed the concrete to achieve a smooth and even surface.**
 - When slab and walls are concreted at the same time, finish the concreting for the walls first and start slab concreting over the wall concreting where it was started first. This should provide enough time (minimum 3 hours for walls up to 3m high) for wall concrete to settle before the slab concreting takes place over the particular wall.

10. Visual Inspection During Concrete Pouring

Ongoing visual inspection during concreting for vertical alignment and plumb of the formwork is required. The pour should be stopped or continued at reduced speed if any areas start to move and continued only after the concrete has an initial set.

Wood/steel props, plywood, etc should be ready to provide temporary bracing should any problems develop.

11. Concrete Vibration:

Proper concrete compaction is paramount to prevent voids in the concrete. Pay special attention to the sides of all openings, bulkheads and any areas that have a higher than normal concentration of steel.

- Dincel-Form is a non-porous material which does not absorb water unlike masonry blocks, fibre cement or plywood forms. This increases the flowability of concrete and eliminates honeycombing of the concrete.
- It is recommended that tapping walls with a rubber mallet or hand rodding would assist. **However, the best practice is to use 25mm pocket vibrators in all cases. The vibrator forces concrete mix slurry to fill the voids at the snapping joints which further assists waterproof and render finish performance.**
- **Vibrators that are bigger than 25mm shall not be used.** Extreme care is required when vibrators are used as they can damage the web-links between each face of the formwork which may cause bulging.

12. Concrete Curing:

In the case of conventional removable floor formworking being used, the construction of walls can continue as soon as the floor slab is ready to be worked on.

In the case of permanent floor formworking, i.e. pre-cast planks or permanent metal formworking directly bearing on the **DINCEL®-WALL** without being propped; Concrete poured into the forms shall be cured for either 3 days at a minimum temperature of 10°C or for the time necessary to attain 35% of the specified 28-day compressive strength. Refer Item No: 13 for concrete mix design parameters.

13. Concrete Design for Specifiers:

(A) Walls with Vertically Positioned Dincel Panels

- (a) Walls associated with in-situ reinforced or post-tensioned concrete floors.

Floor to floor concreting cycle can be as small as 4 days with **DINCEL[®]-WALL**. Australian construction practice requires up to 3 consecutive floor formworking/back-propping to be kept in place for multi storey building construction. This will exert at any time onto **DINCEL[®]-WALL** at 3 x 4 days = 12 days dead weight of 3 floor slabs (typically each slab having 7.5m of loading width), 3 storeys in height **DINCEL[®]-WALL** dead weight and construction live load from the floors. For these reasons compressive strength of **DINCEL[®]-WALL**'s concrete to be minimum 3 MPa at 7 days.

- (b) Walls associated with precast concrete floor systems. This way, **DINCEL[®]-WALL** must be poured prior to placement of precast planks. The concrete compressive strength to be specified by the design engineer to suit precast flooring installation.

(B) Walls with Horizontally Laid Dincel Panels for Factory – Warehousing

The main issue is concrete placement. No more than 1m concrete lifts, 150mm slump and good vibration are required. The concrete mix is to be as required by the Design Engineer.

14. Steel Reinforcement Issues

Heavy and long horizontal bars placement without caution may cause damage to the polymer webs which may result in bulging/blowouts.

Dincel Construction System does not require the presence of steel reinforcement for shrinkage and temperature control purposes unless applied loads requires additional tensile capacity in the concrete as confirmed by the University of New South Wales' Dincel Structural Engineering certification. (For further explanation refer Dincel's website: type in "Common Engineering" in the search engine).

Unless otherwise instructed by the structural design engineer for the project, the following principles apply for reinforcements.

- **Basement or retaining walls** – No horizontal crack control reinforcement required (TBC by design engineer), vertical bars are required for the applied earth/water pressure loading.
- **The remaining walls other than basement, retaining and shear walls.** These walls usually carry compressive loadings. There is no need to place vertical or horizontal reinforcement unless the walls are used as shear walls or deep beams. Dincel Construction System details only show dowel bars and 'L' bars at the bottom and top of the walls to maintain stability during earthquake or wind loadings. (Refer Design Engineer).
- **Shear walls** – A lift shaft or any other concrete element can be used as a shear wall for the purposes of applied wind and earthquake loadings. This necessitates that both horizontal and vertical directions reinforcement must be used.

Table 2 – Net Concrete Quantity excluding wastage for pump hose/hopper, etc.

	200mm	110mm	155mm
Per cubic metre of concrete	5.5m ² of wall area	9.5m ² of wall area	6.67m ² of wall area
Per square metre of wall area	0.182m ³ of concrete	0.105m ³ of concrete	0.15m ³ of concrete

TABLE 3 – CONCRETE MIX SPECIFICATION (Refer Item No: 13)

Cement Type:	Type GP in accordance to AS3972. Fly ash in accordance with AS3582.1 may be used as cement replacement and/or improve workability.
Characteristic 28 Days Compressive Strength:	3 MPa to 100 MPa (as specified by design engineer). AS3600 allows up to 100 MPa. Dincel has already successfully utilised 80 Mpa concrete.
Design Target Slump and Aggregate Size:	Refer Table 1 – Item No: 9 – Concrete Placement
Vibration:	VERY IMPORTANT – Refer Item No: 11 – Concrete Vibration.
Concrete Pump Nozzle Size:	Nozzle with internal diameter of 75mm maximum. (100mm nozzle size can be considered provided the concrete flow pressure is controlled).

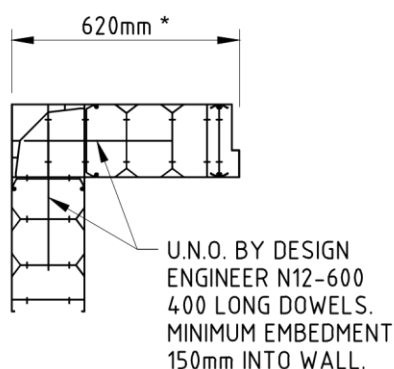

PLAN- CORNERS

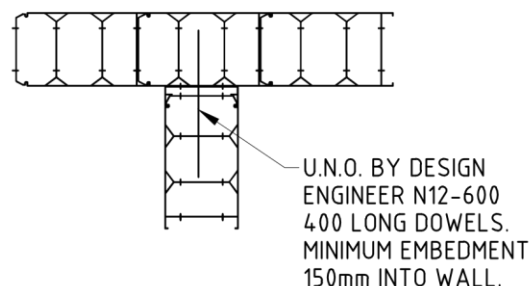

PLAN- 'T' JUNCTIONS

JUNCTION DETAILS WHERE STRUCTURAL CONTINUITY NOT REQUIRED

(I.E. NOT SHEAR WALLS)

THE ABOVE PRINCIPLES RECOMMENDED TO BE ADOPTED UNLESS NOTED OTHERWISE BY DESIGN ENGINEERS.

* SIZES SHOWN MINIMUM ARE FOR FORMWORK/CONCRETE PLACEMENT PURPOSES ONLY. REFER TO STRUCTURAL ENGINEERS DESIGN FOR MINIMUM SIZES FOR LOAD BEARING PURPOSES.

15. Propping at Wall Ends and T Junctions

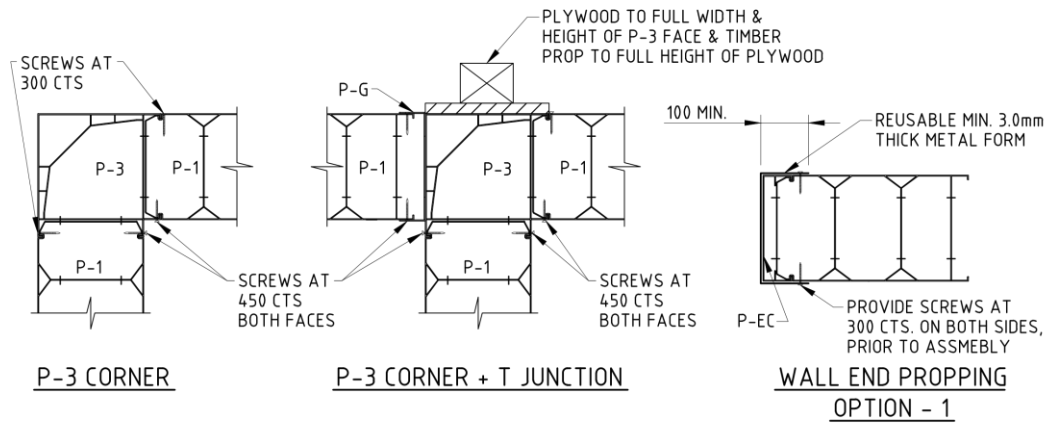

NOTE: SCREWS AT FACADE WALLS EITHER TO BE STAINLESS STEEL OR TO BE REMOVED BEFORE APPLICATION OF EXTERNAL FINISHES.

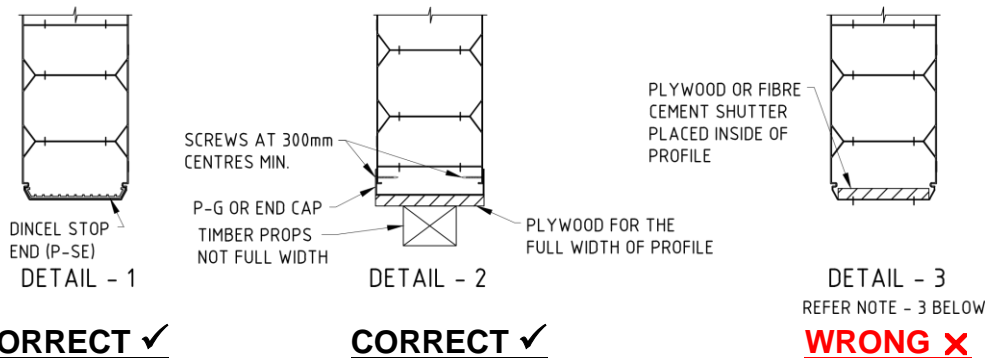

DINCEL WALL/COLUMN END PROPPING

Notes

1. Timber props must be braced by straps or external diagonal props so that it does not move during concrete pouring.
2. Concrete pressure is at maximum at the wall/column ends. Pour concrete in accordance with this manual and keep the vibrators (if any are used) and pump nozzle at least 500mm away from the wall/column ends.
3. Detail 3 above is not appropriate for fire/rotting issues (if plywood is used) unless the stop ends are removed by cutting. **The formworker must use this detail at his/her own risk. The formworker must use this type of propping at his/her own risk.**

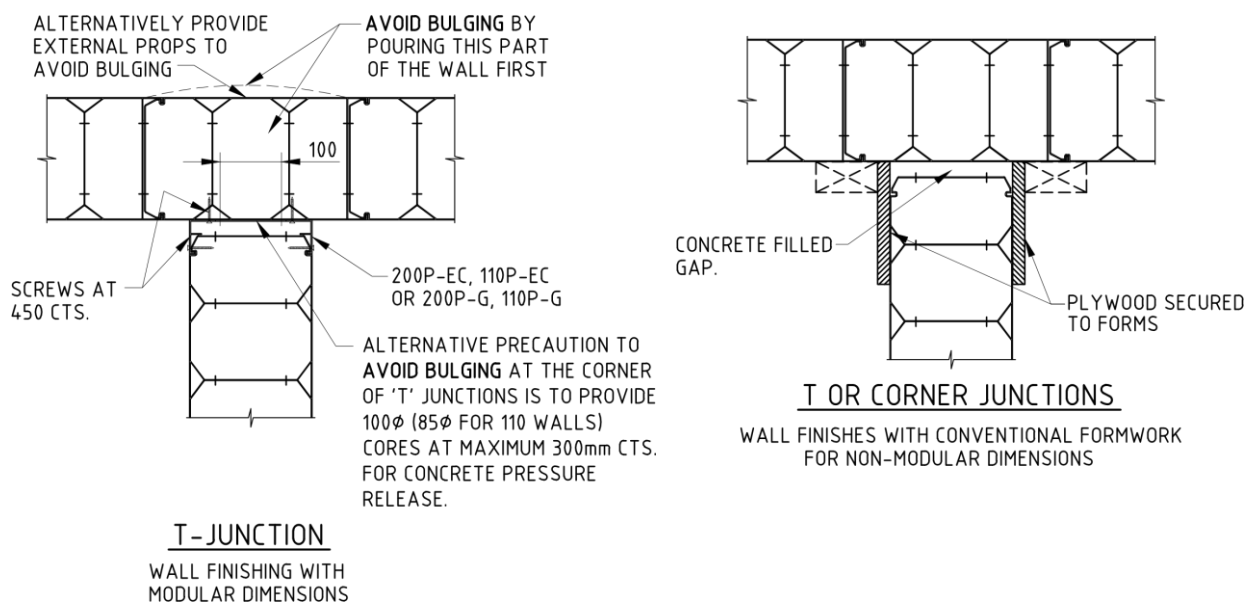

16. Bracing and Propping at Openings:

The reader should also refer to K-15 notes for wall/column end propping.

Installers cut and remove window/door openings after concrete pouring. This minimises workmanship faults associated with formwork/propping and achieve significant time savings, or alternatively, a window lintel can be formed as follows:

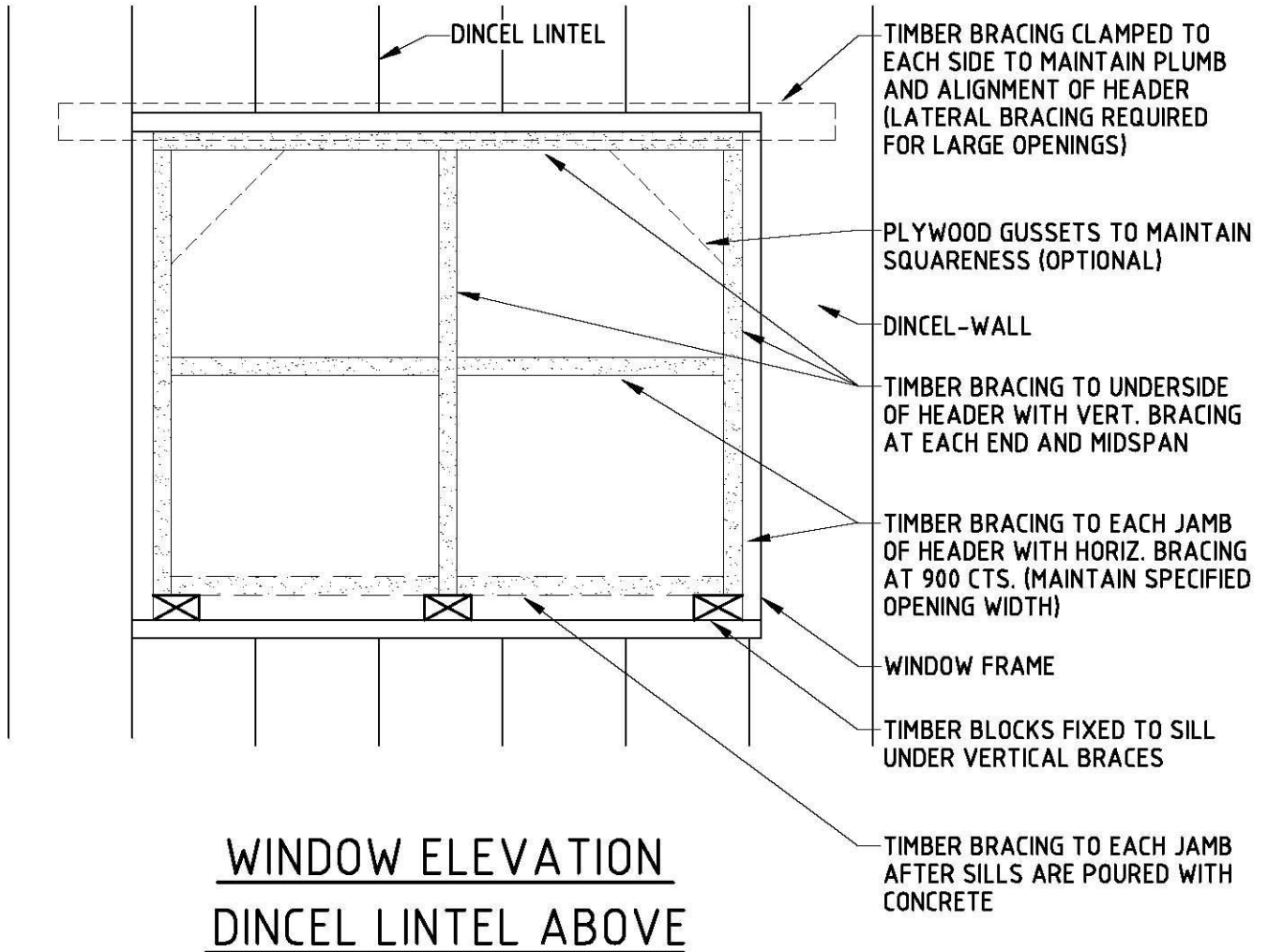

METAL FRAME LIPS SCREWED TO PROFILES AT 250mm CTS.
OR
ALTERNATIVELY PROVIDE PROPS ON BOTH SIDES

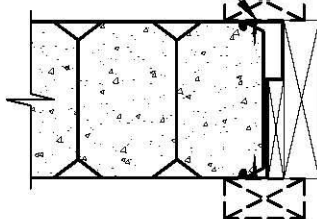

WINDOW JAMB-PLAN

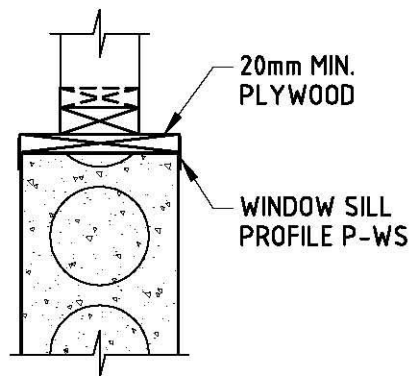

SILL SECTION

WINDOW FRAME BRACING DETAILS

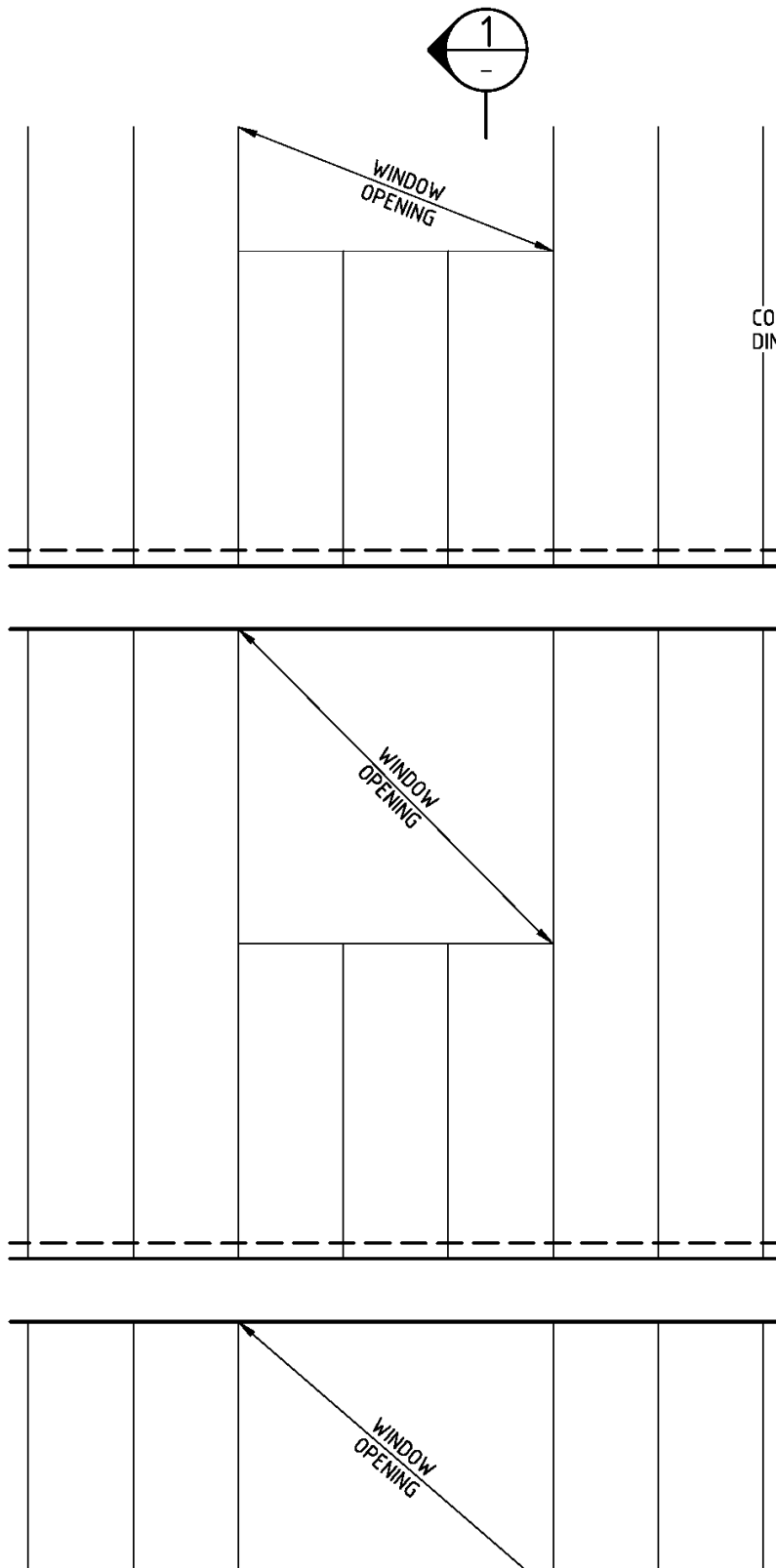

WINDOW ELEVATION WITHOUT
DINCEL LINTEL ABOVE

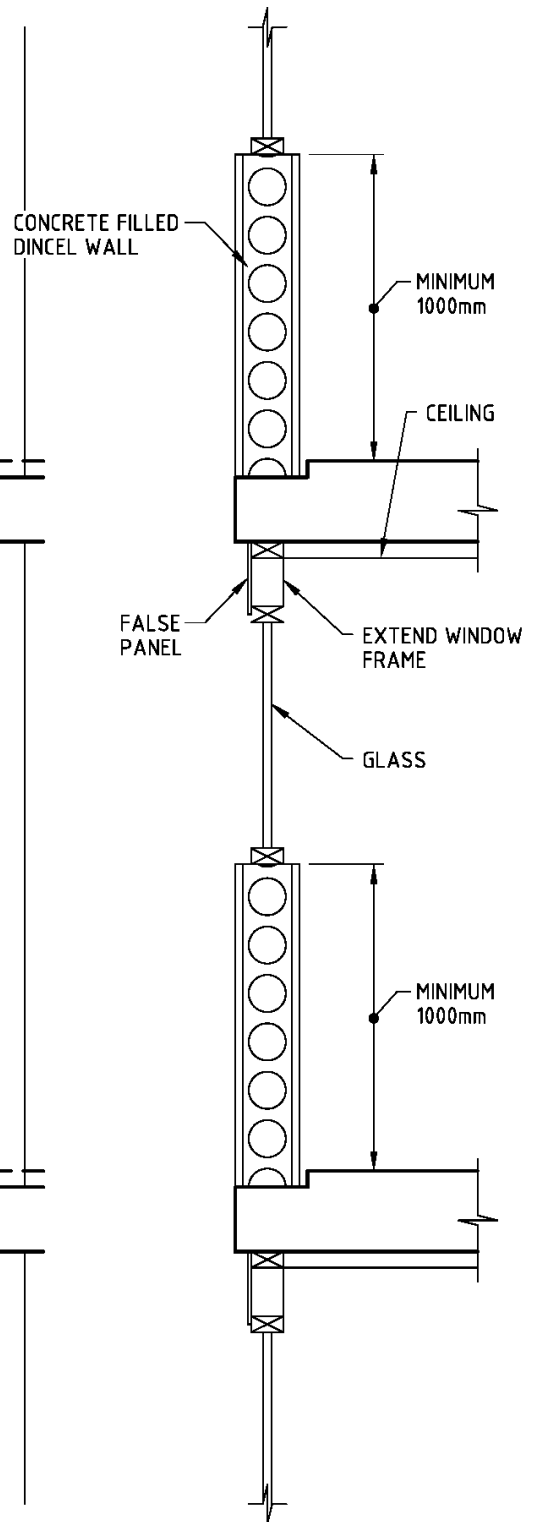

SECTION AT
WINDOW HEAD

SECTION 1

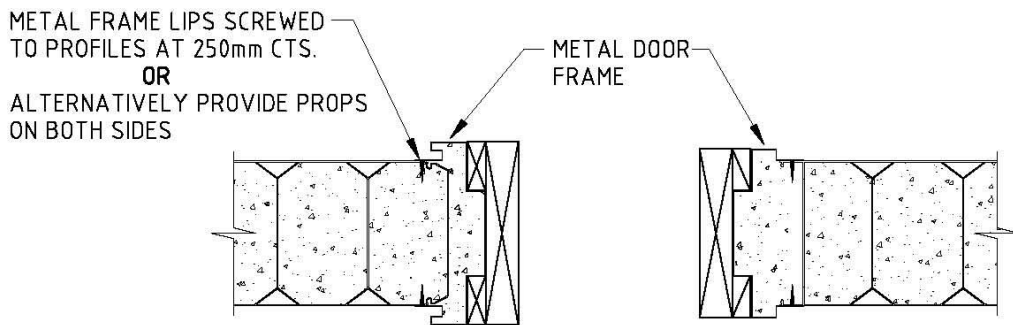
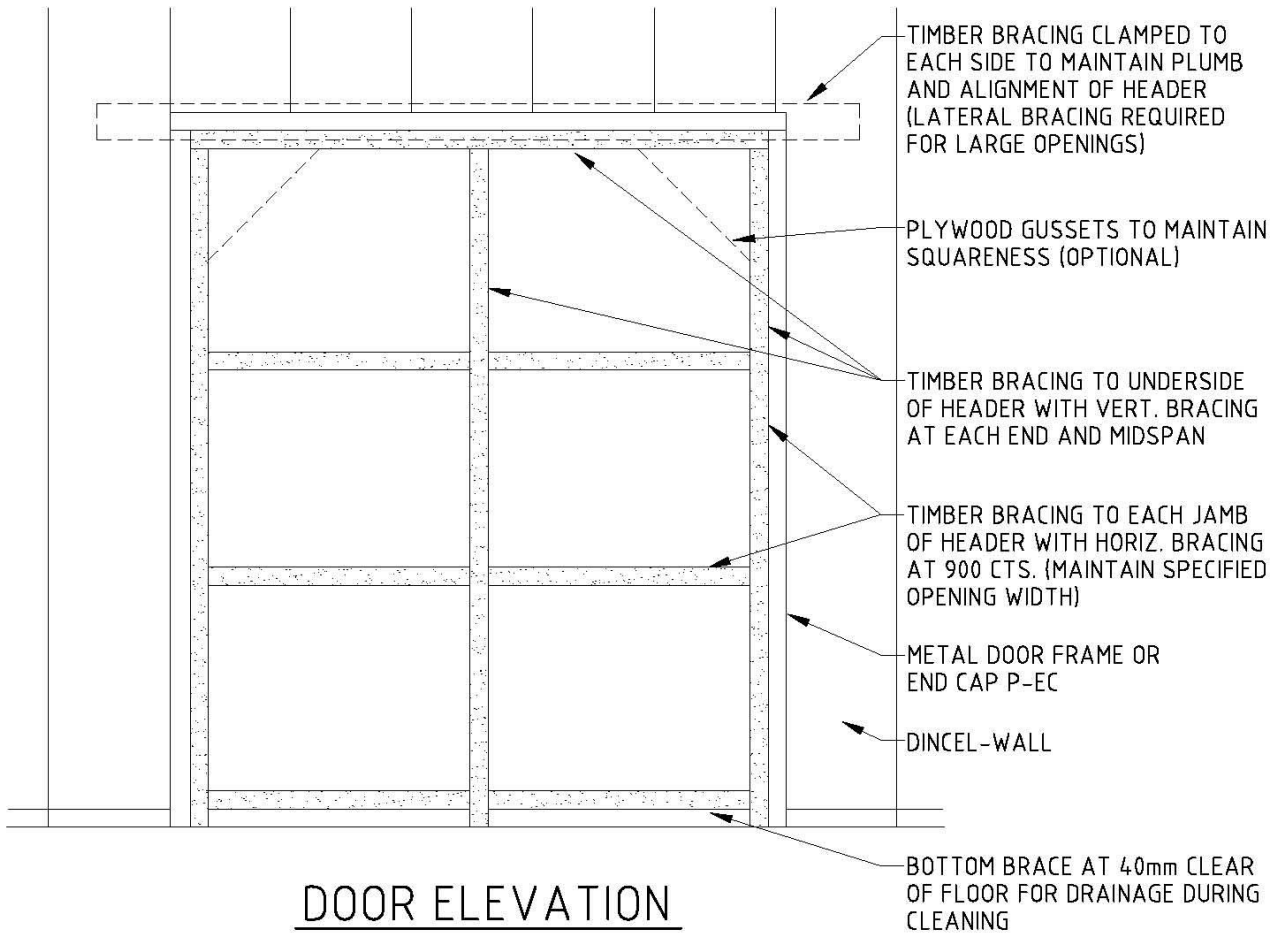

PLAN AT METAL DOOR FRAMES

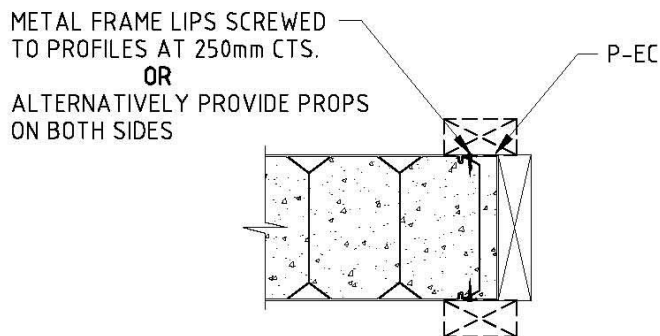

PLAN- SQUARE FINISH WITHOUT DOOR FRAME

DOOR FRAME BRACING PLAN

17. **DADO WALL CONSTRUCTION** – refer: www.dinzelconstructionssystem.com “Dinzel’s Alternative to Tilt-Up and Precast Factory/Warehouse Walls”

DADO WALL CONSTRUCTION

BENEFIT: PRECAST WALLS ARE REQUIRED TO BE PLACED BEFORE THE PLACEMENT OF WALL GIRTS AND FASCIA PURLINS, HENCE RIGGERS MUST COME BACK TO THE PROJECT AFTER THE INSTALLATION OF PRECAST WALLS. DINCEL IS INSTALLED WITHOUT THE NEED FOR CRANAGE, ALLOWING THE RIGGERS AND DINCEL WALL INSTALLERS TO WORK SIMULTANEOUSLY WHICH ELIMINATES THE LOSS OF TIME ASSOCIATED WITH PRECAST WALLS.

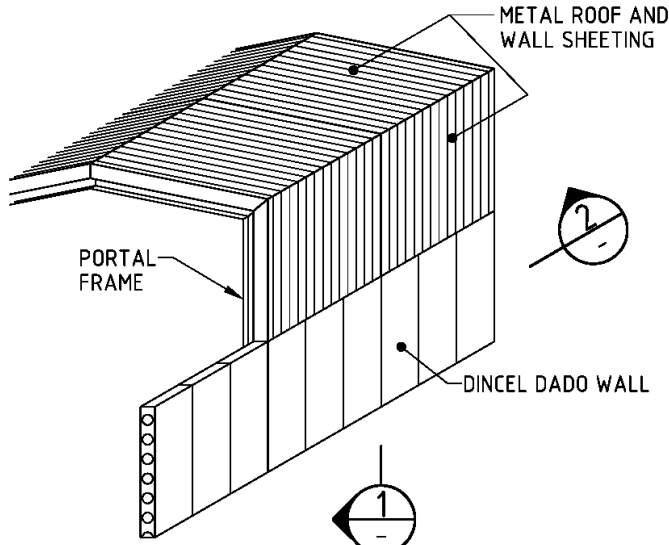

**ISOMETRIC VIEW
FACTORY/WAREHOUSE**

CONSTRUCTION SEQUENCE

- 1) PLACE PILES/PADS FOR PORTAL FRAMES
- 2) PLACE PORTAL FRAMES
- 3) PLACE PURLINS, WALL GIRTS AND BRACING
- 4) PLACE DINCEL DADO WALL SIMULTANEOUSLY WITH ROOF SHEETING
- 5) POUR SLAB PRIOR OR AFTER THE INSTALLATION OF DINCEL WALL TO SUIT FOOTING DETAILS
- 6) PLACE WALL SHEETING

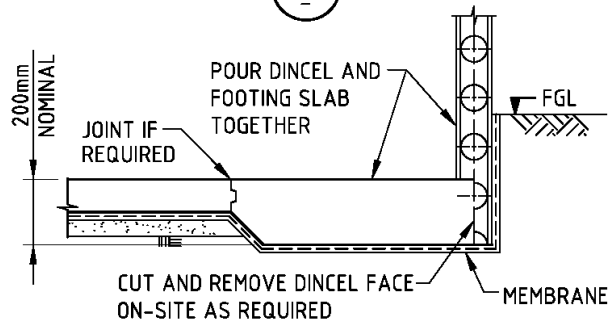
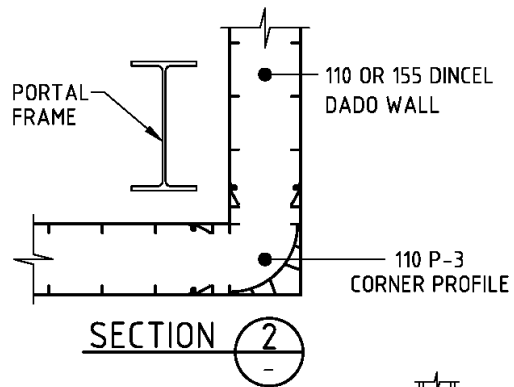

ALTERNATE FOOTING DETAIL

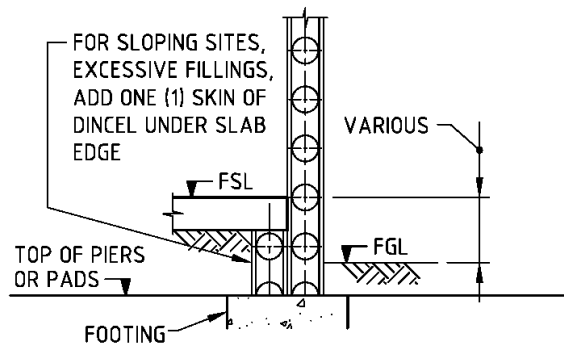
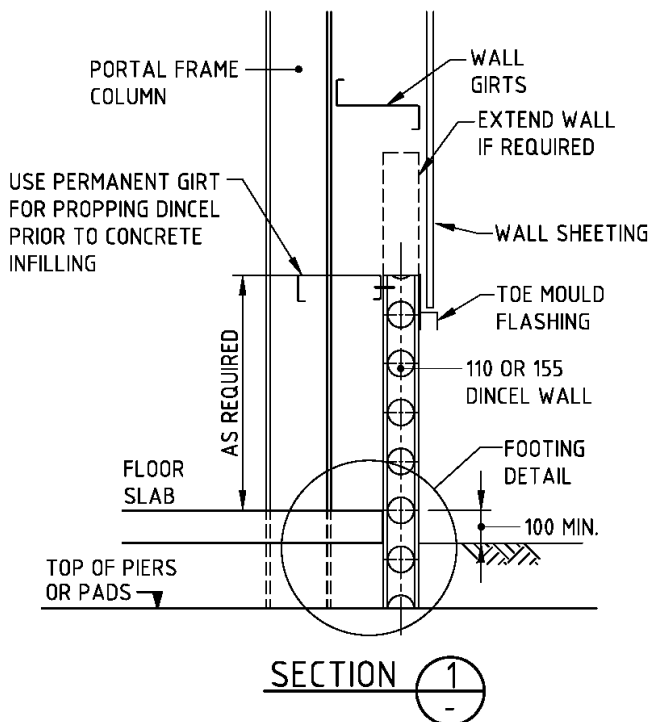

ALTERNATE FOOTING DETAIL

18. CONVENTIONAL BUILDING WALLS – refer Dincel website – Installation Video for the following methodologies (e.g. building walls or retaining walls laid **VERTICALLY**).

- Each subsequent vertically placed Dincel panel snap connects to each other, the panel heights exceeding 4.5m needs assistance to complete the snapping action either at the top or bottom of the profile being installed.
- The most practical way of wall erection depends on the type of flooring that is placed over the **DINCEL®-WALL**. For example, if in-situ floor slabs with removable formworks are used, or even precast or preformed metal deckings which are supported in such a way that no loading is exerted on the wall forms; this allows **the safest and most logical way for the concrete walls to be installed and poured from the deck over. This way the walls can be poured first and floor slabs later, even on the same day.**
- For the purposes of safety and ease of the bracing requirement, vertically erected **DINCEL®-WALL** panels can be placed the following way.

• **Installation Methodology 1 – Building With Safety Scaffoldings**

This installation methodology is required for façade walls (i.e. building periphery walls) installation with presence of safety scaffoldings for fall protection of the workers.

This methodology consists of walls being stabilised by diagonal bracings as shown below.

The walls being erected consist of bottom tracks P-G or P-EG or timber 100mm x 50mm walers secured to the floor/footing below. The top of the forms can be secured to the floor/footing with adjustable length diagonal bracings and mild steel or aluminium angles along the top of **DINCEL®-WALL**. The wall is braced to the floor slabs as illustrated in the figure below. **The concrete is poured from mobile scaffolding if there is no floor formwork to pour concrete for cases such as walls immediately under conventional roofs.**

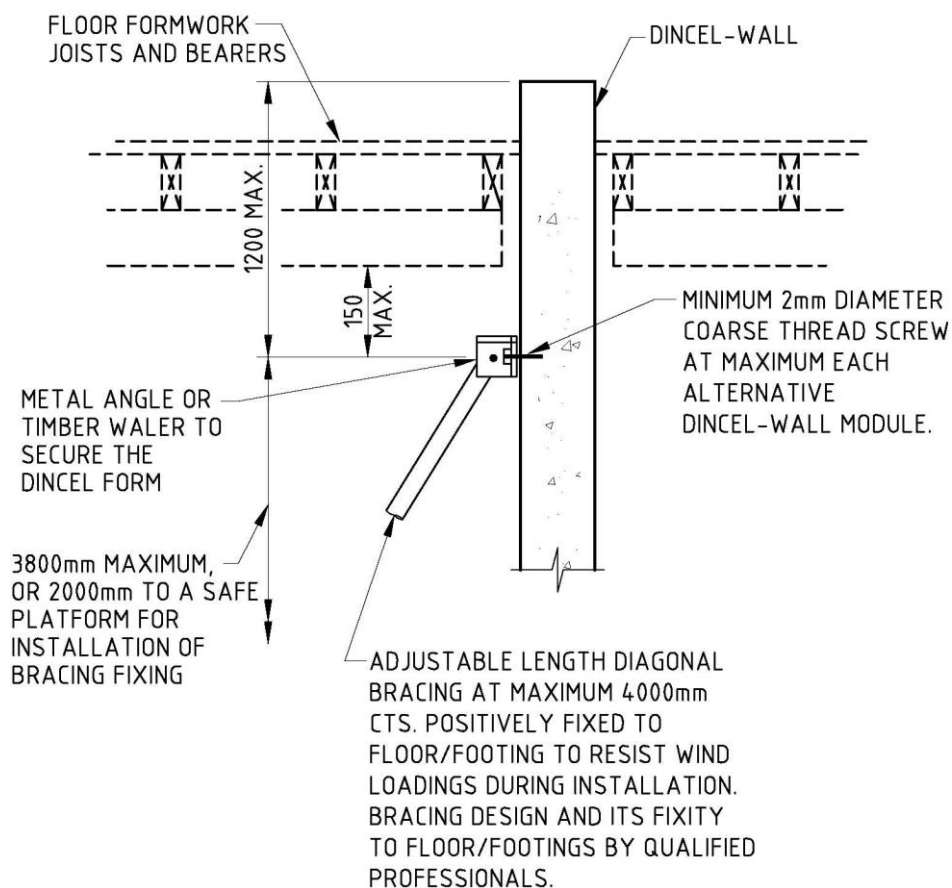

➤ Installation Methodology 2 – Building With Safety Scaffoldings

This is the most popular form of installation currently adopted by the formworking trade where the floor formwork platform is available (i.e. multi-level buildings). This system eliminates the use of wall bracings.

This installation methodology is required for façade walls (i.e. building periphery walls) installation with presence of safety scaffoldings for fall protection of the workers.

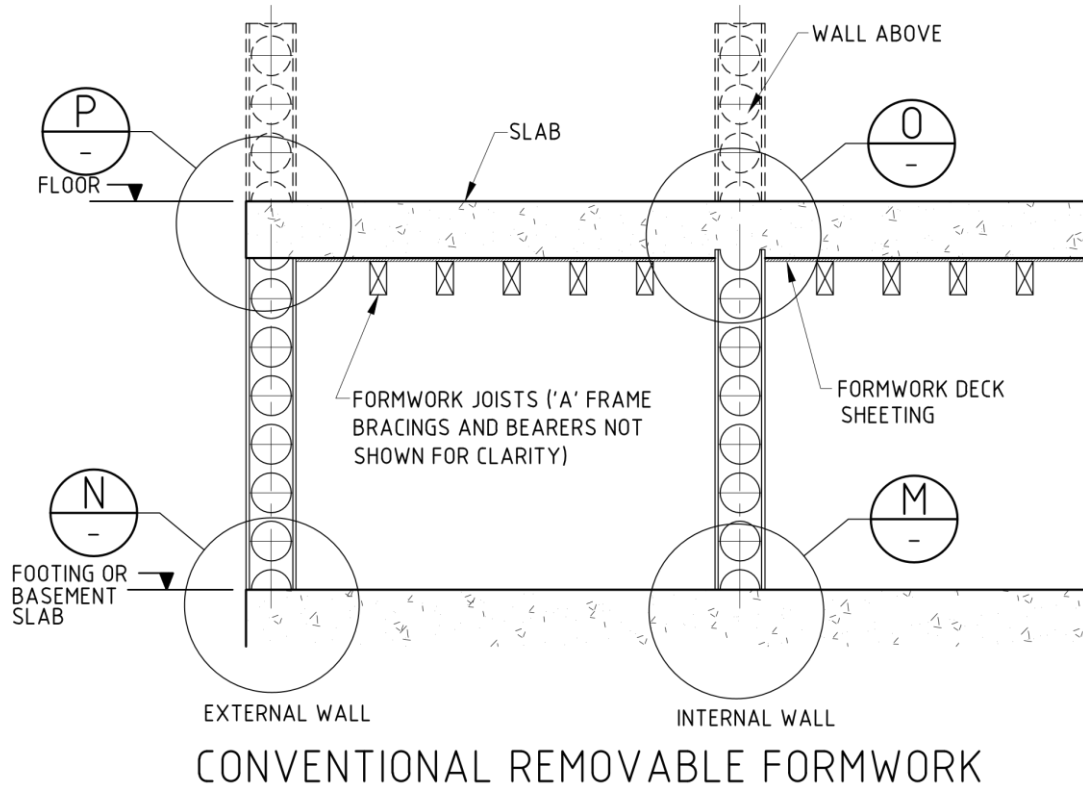

PRINCIPLE

The following methodology assumes that the building periphery is secured by the presence of approved scaffolding systems.

- Mark positions of walls on footing or slab.
- Formworker places conventional formwork. A frames, bearers and joists.
- Position the formwork deck sheeting on the floor joists by laser lining the wall positions already marked on the footings/floors.
- Repeat this procedure to create gaps between deck sheetings to fit Dintel-Form.
- Lower Dintel-Forms from formworking decks through the gaps created. Alternatively, if the walls are installed by the formworking trade, deck sheeting on one side of the wall can be installed first, then stand the Dintel-Forms against the formed deck and finish the deck sheeting on the opposite side of the Dintel-Forms. The method of using the formworking deck ensures that the top of the walls are kept straight and braced by the formwork deck simultaneously, the bottom of the walls are stabilised by the P-G profile or timber walers.
- If the gaps in the deck to lower the Dintel-Forms are to be left unattended, the gaps must be covered for safety reasons.
- The perimeter walls can be installed by simply lowering the profiles from the formworking deck. However, the top of the wall profiles need to be further secured to the formworking deck in the case of edge conditions where decking is not continuous on both sides of the Dintel-Wall.
- The securing of the Dintel-Form at the edge of the formwork deck can be ensured by way of adopting the diagonal bracing shown in previously explained [installation methodology 1](#) or by securing the Dintel-Form to the formwork deck's sheeting itself. There are a number of different fixity details that can be applied in between the Dintel-Form and formwork deck sheeting, however, the following detail found the most acceptance by many formworking trades.

DIRECTION OF PROFILE ASSEMBLY, →
MALE PROFILE SNAPS INTO FEMALE PROFILE AFTER
INSTALLATION OF SCREW AT THE FEMALE PROFILE LEG AS SHOWN BELOW.

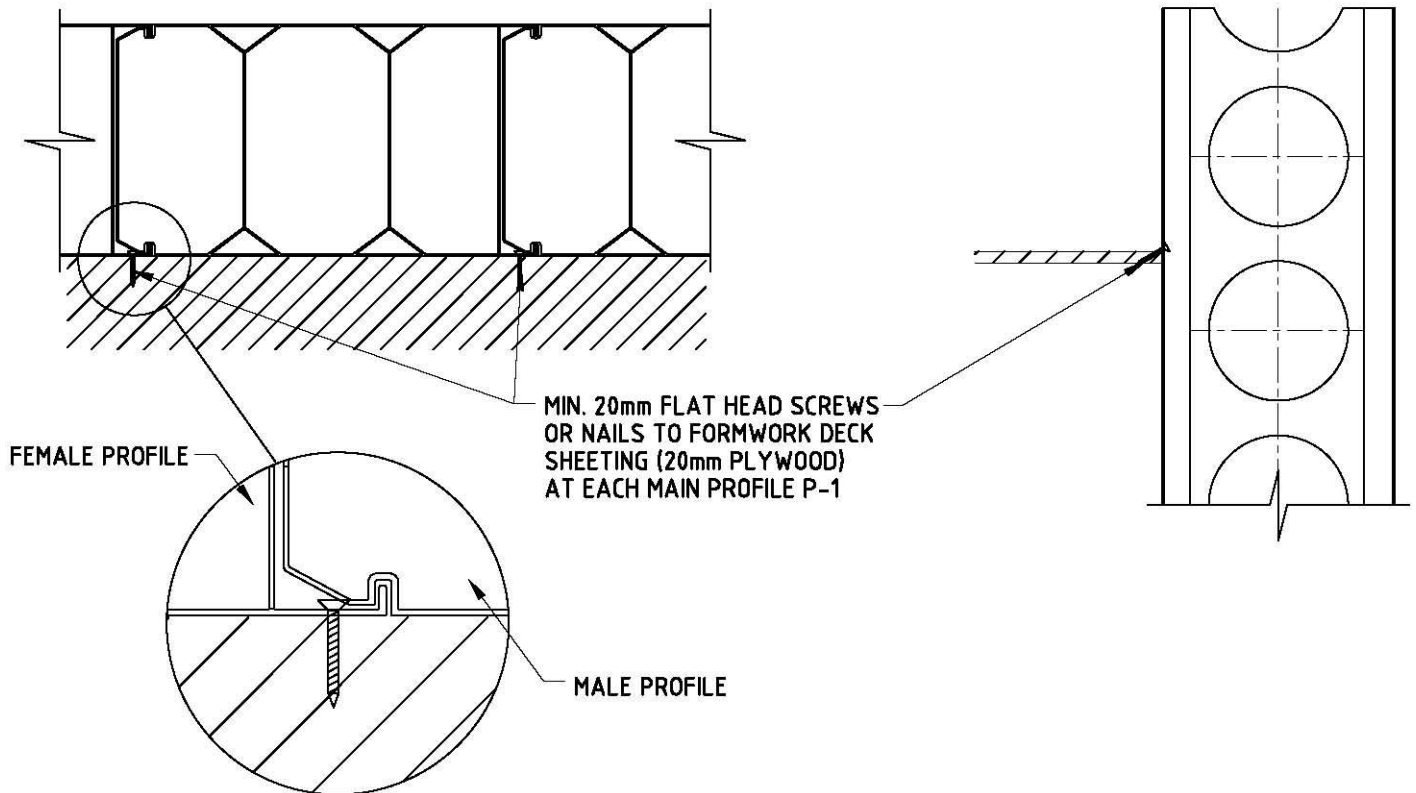

DETAILS SHOWING SECURING OF DINCEL WALL TO PLYWOOD FORMWORK DECK

ADVANTAGES:

- Work by a single trade.
- Fast installation of the formworking deck and Dincel-Forms simultaneously.
- Elimination of conventional diagonal wall bracings.
- Continuation of the formworking trade for the project without leaving the construction site.
- Simple and safe to install, lightweight, wastage minimisation.
- Safer concrete pouring from the formed deck.

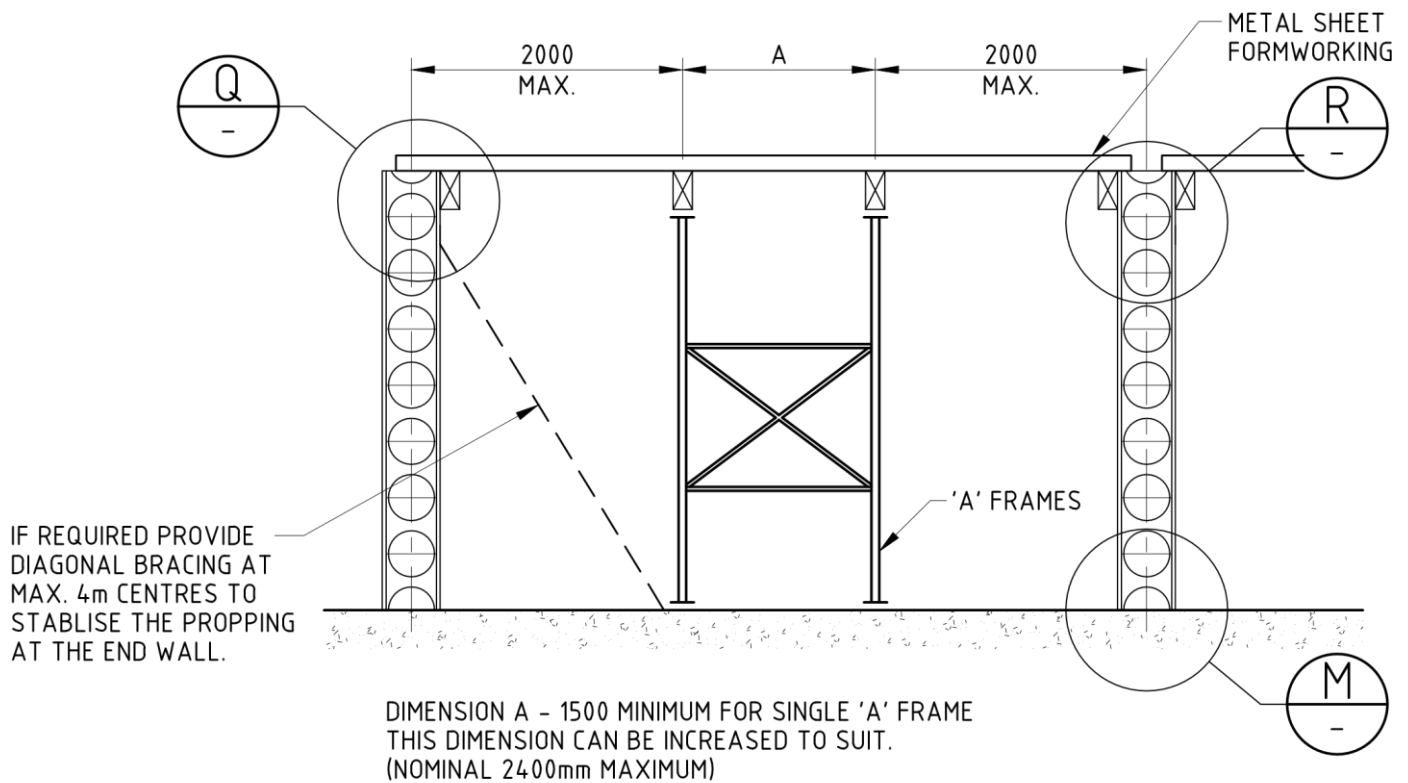

METAL FORMWORKING FOR SLABS

PRINCIPLE

The following methodology assumes that the building periphery is secured by the presence of approved scaffolding systems.

- Installation can take place by standing the walls up with the assistance of diagonal wall bracings and pouring the walls with the assistance of mobile scaffolding. However, the following methodology can also be adopted.
- As shown on the above detail place the 'A' frames and extend bearers to the walls as struts. Prop Dintel-Form from struts with the assistance of plywood or timber as shown on Detail-K above.
- Place metal deck on joists over the 'A' frames, bear metal deck minimum 50mm over Dintel-Form.

The important issues to implement are:

- Use boom pump, so the pump lines are not dragged on the metal decking.
- Pour walls from the metal deck into forms.
- Refer engineering recommendation for the removal of props.

ADVANTAGES

- Metal formwork does not require stripping and is easier and faster to install.
- Above methodology gives the opportunity of safer concrete pouring from a deck, less or no diagonal bracings for the walls.

Installation Methodology No: 3 – Dintel – Façade Wall Installation WITHOUT SCAFFOLDING For Fall Protection

This methodology is only suitable for 200mm Dintel Walls and is not recommended with the 110mm Dintel Walls.

The installers who are interested in this methodology are recommended to refer to:

www.dintelconstructionssystem.com

Type in the word “scaffolding” in the search button in the Home Page to view the document titled “**DINCEL ELIMINATES SCAFFOLDING**”.

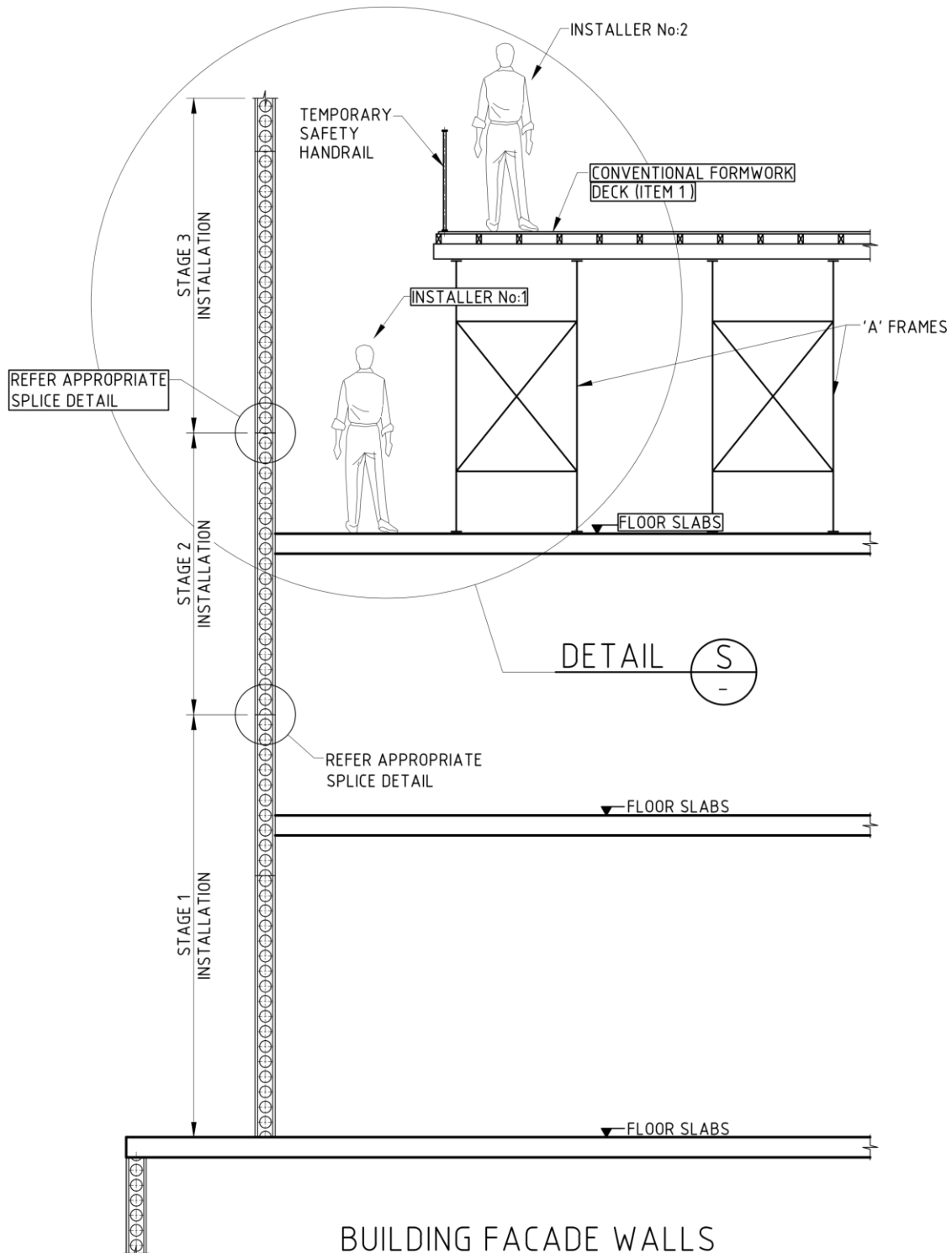

BUILDING FACADE WALLS WITHOUT SAFETY SCAFFOLDING FOR FALL PROTECTION

19. ENGINEERING DESIGN ASSUMPTIONS TO BE ADOPTED FOR INSTALLATION OF DINCEL-WALLS

- a. Dincel-Form is capable of handling the pressure of wet concrete as defined in AS 3610 Formwork Code provided the concrete pouring practices of this manual as explained in Items K6, K8, K9, K10 and K11 are followed.
- b. The Dincel-Form receiving the concrete filling needs to be stabilised against forces such as wind loadings.

- (i) The multi-level buildings having formed deck above – Refer Item No: 18.

The uniqueness of this methodology unlike the other walling systems does not require conventional diagonal bracings when the conventional floor formworking and bracing are used.

- (ii) Dincel-Form requiring bracings for installation purposes.

This need may arise if there is no formwork decking above as in b. (i) above to stabilise Dincel-Forms.

The forms requiring to be stabilised for concrete pouring normally utilise diagonal bracings of metal or timber members.

The wind forces can vary depending on the position and the height of the wall. For example, single level structures require less stringent bracing requirements than the walls located at the top of multi-level buildings. A qualified engineer can determine wind forces in accordance with AS 1170 – Loading Code, depending on the specifics of the project. The bracing design requirement of Dincel-Wall is no different than what is required from conventional formworks as stated in AS 3610 Formwork Code.

The installer for Dincel-Form may adopt the bracing methodology illustrated in Item 18 – Installation Methodology Number: 1 or 3. AS 3610 Formwork Code does not provide standard solutions for bracing design. For this reason, irrespective of the type of wall formwork system, **the following criteria for bracing design are important and should be addressed by qualified professionals.**

- The magnitude of wind loading, spacings and length of the diagonal bracings.
- The chosen spacing of the bracings to determine the size of the waler.
- The connection of the bracing to a base (e.g. footings, floors, etc.) for all conditions including wind direction reversals.

If any diagonal wall bracings are used in the installation of Dincel-Forms, their design and connections must be certified by qualified professional engineers.

20. CLEANING

Any household detergent can be used for general cleaning purposes.

The Removal of Wet Concrete

The concrete slurry that may spill onto Dincel-Wall can easily be removed if it is washed with high pressure water within 30 minutes before the concrete slurry hardens.

The Removal of Hardened Concrete Slurry

The removal of hardened concrete slurry may damage the walls' surface which could be aesthetically not pleasing for walls without render/paint applications. A piece of P-WS Dincel-Wall module can be placed on top of the walls to prevent concrete slurry spillage onto walls during concrete pouring. The following is a recommendation to assist in removing hardened concrete slurry.

- (i) Make sure that the concrete slurry on the walls is at least two (2) weeks old.
- (ii) Apply hydrochloric-acid diluted to 1-in-10 or less onto the concrete slurry with a brush. Some soft brushing will assist the concrete slurry to absorb the diluted acid.
- (iii) Apply high water pressure to remove the concrete slurry five (5) minutes (or ten (10) minutes maximum) after application of the diluted acid.

21. DAMAGED AREA PATCHING

Surface damage that may have occurred can be patched with a two part polyester resin (similar to the automotive industry's resin filler, Bostik Bog). The damaged part can be cut and removed. If any concrete repair is applied to the damaged concrete component, concrete patching is completed by conventional means. The surface of the patched concrete is then filled with resin of not less than 2mm in thickness to match with the adjacent Dincel-Wall module. Sand and level the dried resin surface and apply etching primer (same as the base for external acrylic render finish) to the damaged module only and paint with matching colour. If the service channels are damaged, the holes are filled with the same resin filler and subject to the same patching treatment.

22. APPROPRIATE GLUE

Plasterboard Gluing – Knauf MastaGrip Stud Adhesive or Gyprock Acrylic Stud Adhesive.

Dincel Components to Each Other – where waterproofing is required, e.g. corners and cut panels, use conventional plumber's PVC solvent cement glue.

23. AID TO SLIDEABILITY OF DINCEL FORMS DURING INSTALLATION

Dirt/dust often accumulates at the construction sites, particularly with exposed earth conditions at the snap-on connection joints of Dincel panels. To assist the slideability of connecting panels use products such as Windex, Ajax liquid spray or a similar product to work as a lubricant.

(L) DETAILING

DINCEL STRUCTURAL WALLS

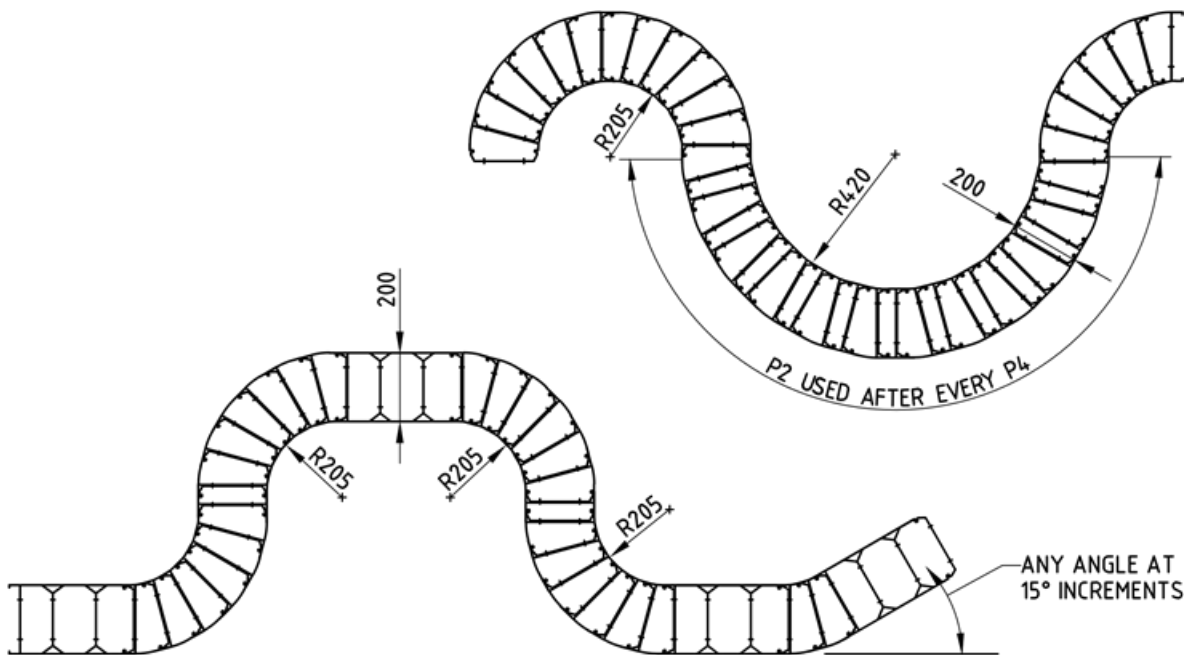
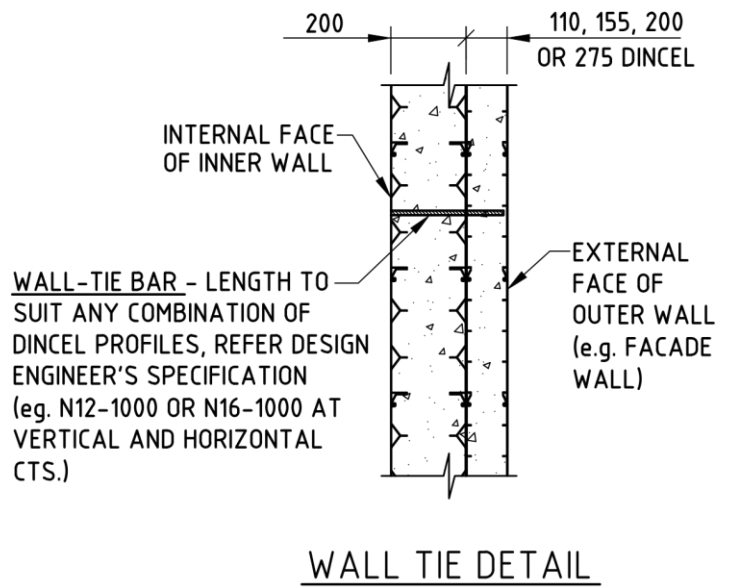
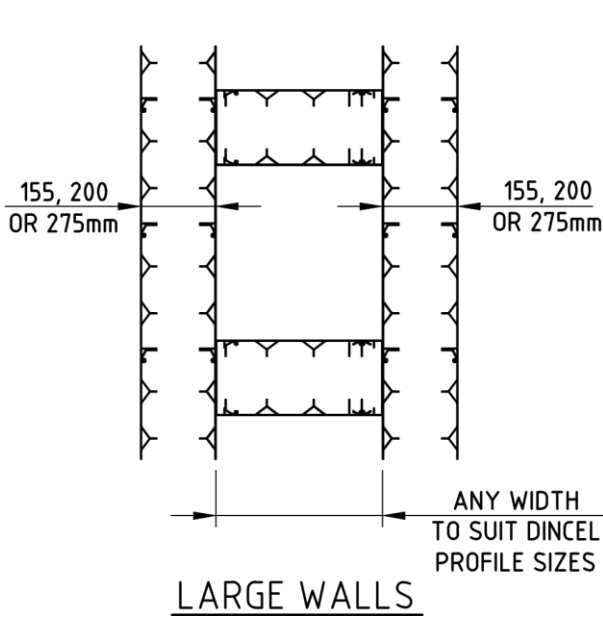
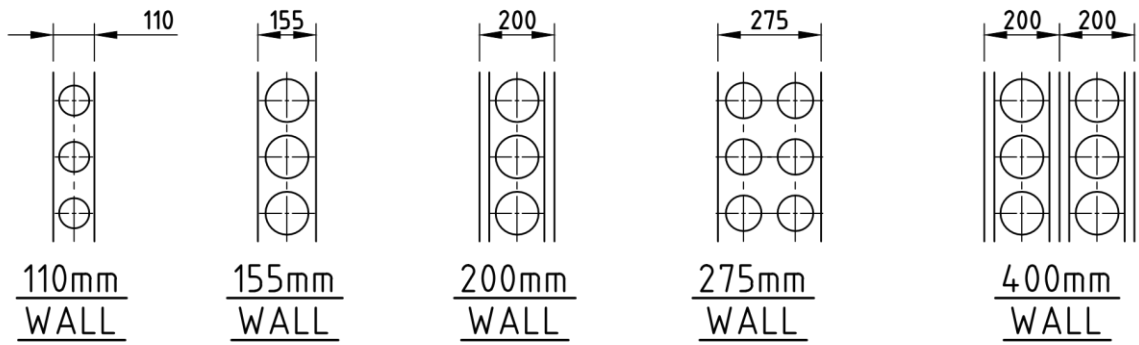

TYPICAL FOOTING DETAILS

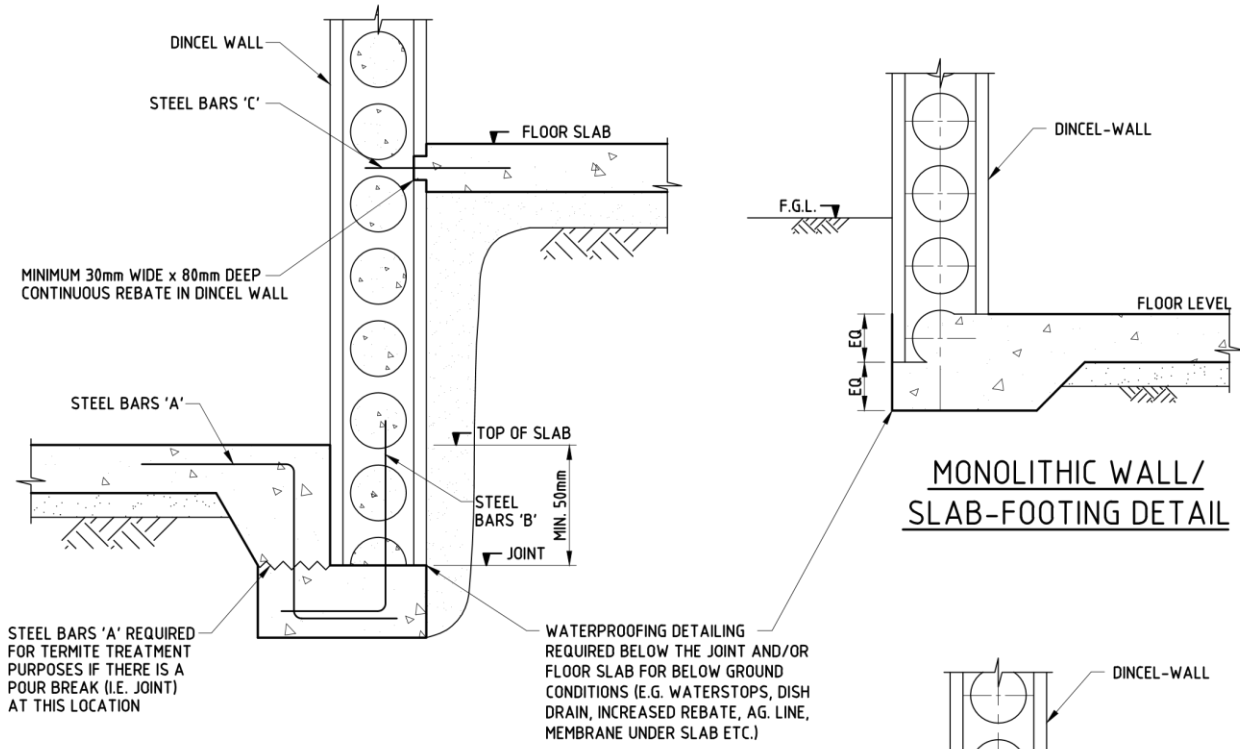

**MONOLITHIC WALL/
SLAB-FOOTING DETAIL**

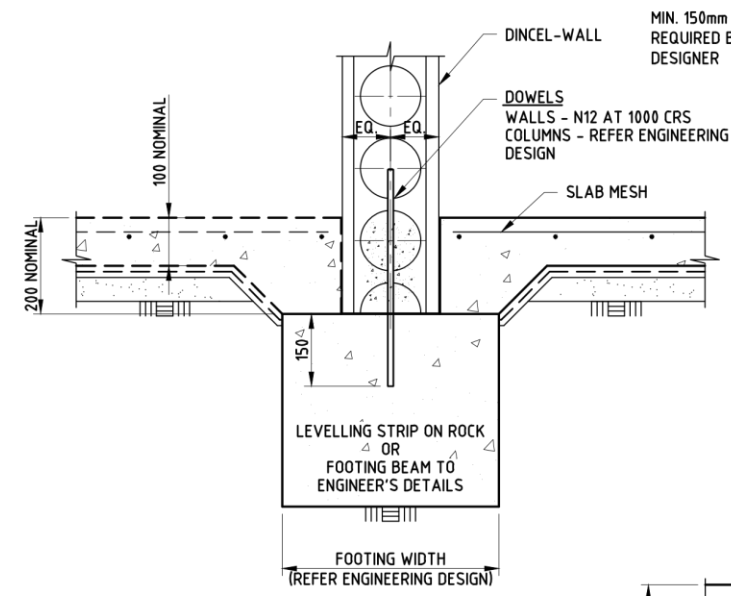

INTERNAL FOOTING DETAIL

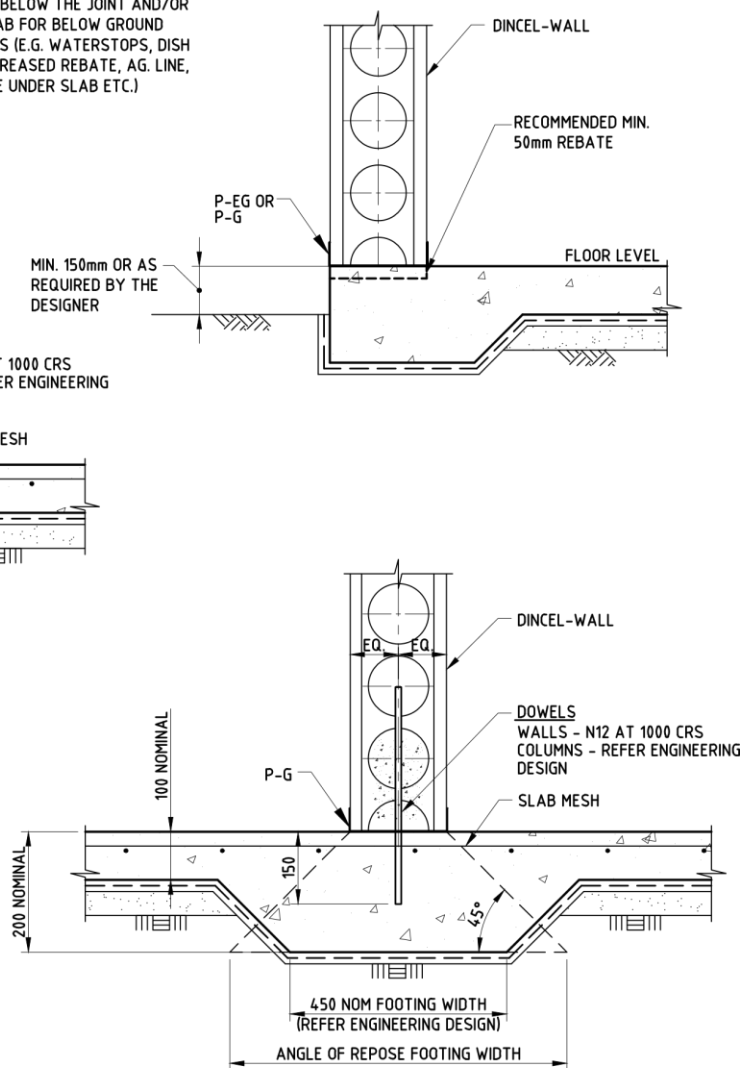

INTERNAL FOOTING DETAIL

ALL FOOTING STEPS MUST BE IN INCREMENTS OF 150mm

NOTE: WHERE FOOTING WIDTH GREATER THAN ANGLE OF REPOSE FOOTING WIDTH, PROVIDE REINFORCEMENT TO FOOTINGS. OTHERWISE PROVIDE MASS CONCRETE FOOTINGS.

DETAIL (M)

TYPICAL FREE STANDING WALL DETAILS

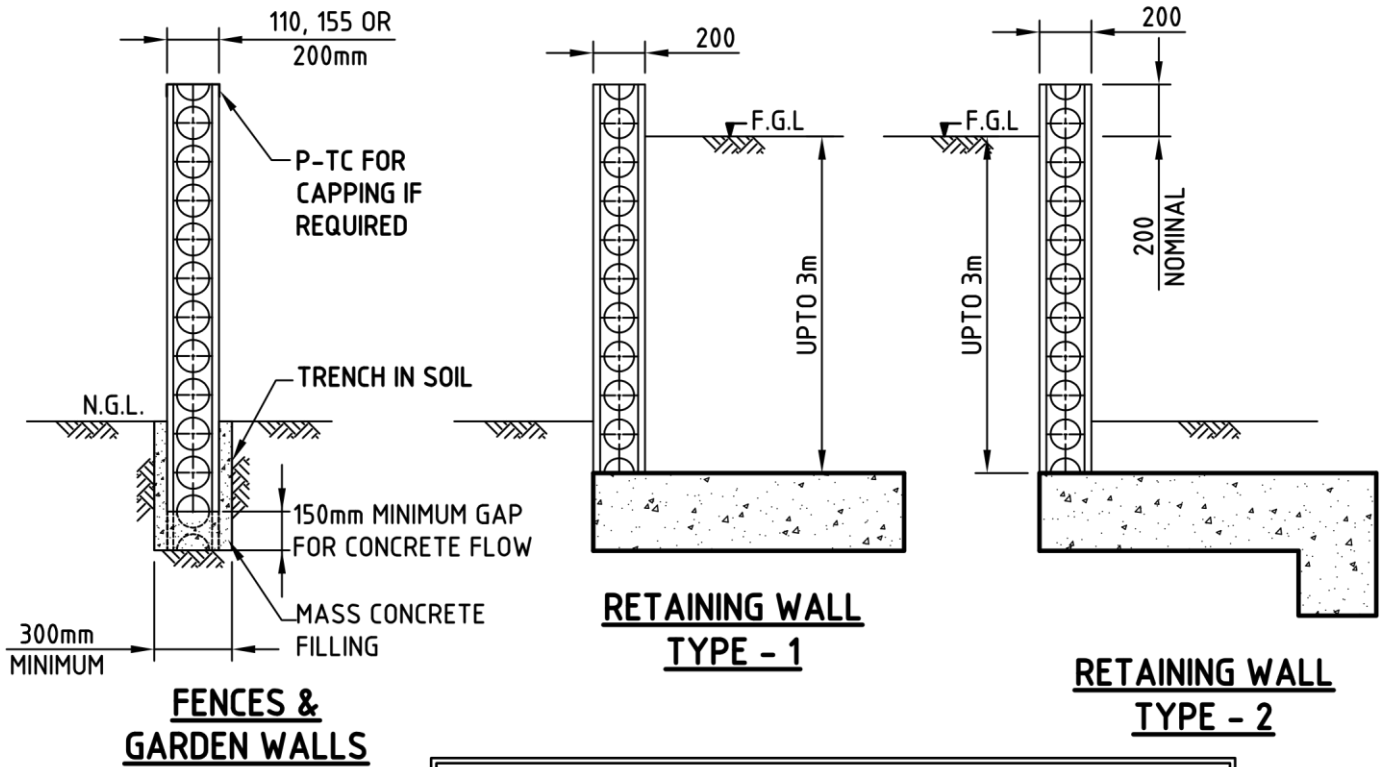

NOTE: REFER TO ENGINEERS DESIGN AND DETAILING FOR DRAINAGE, WATERPROOFING, CONCRETE SPECIFICATION AND REINFORCEMENT.

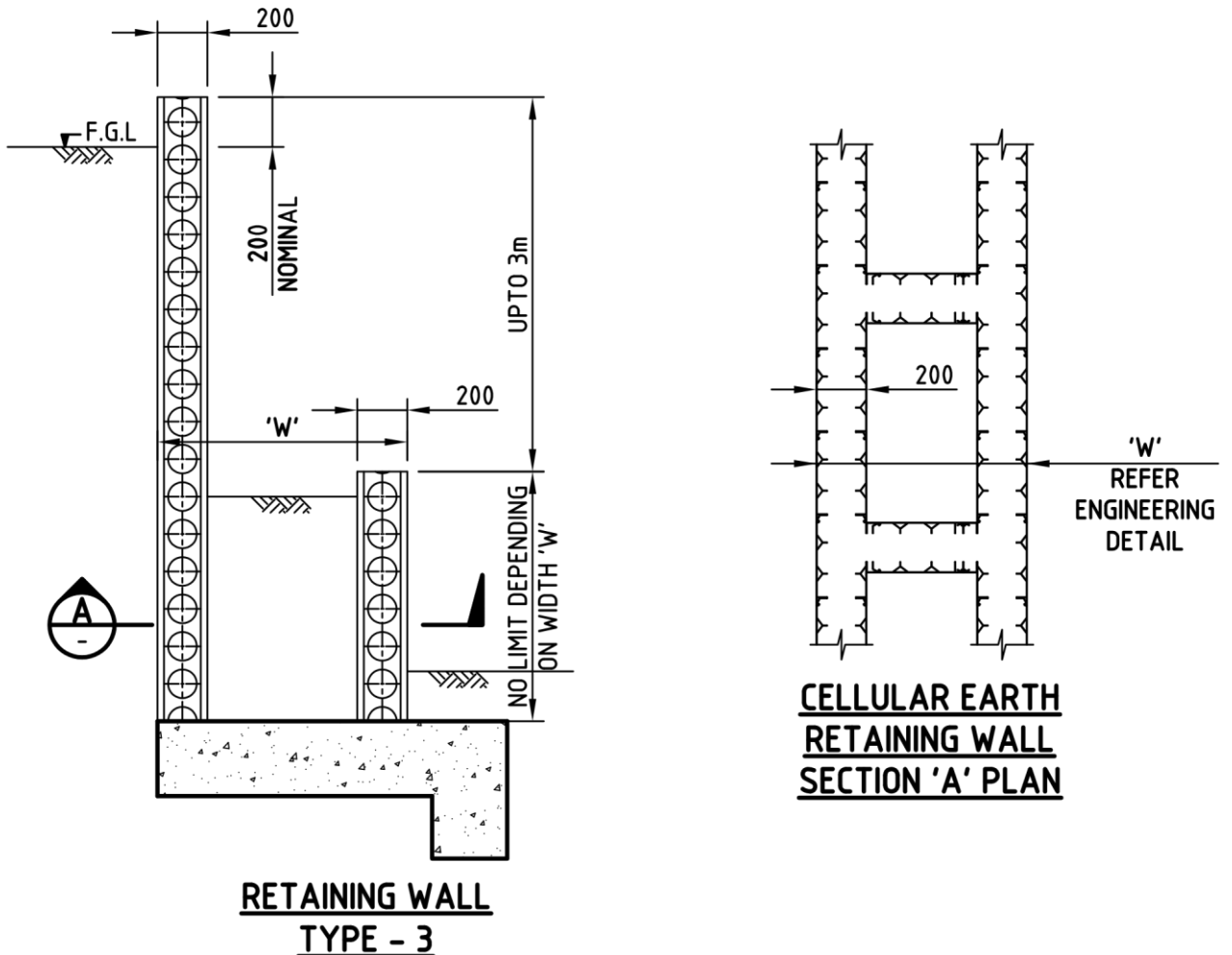

DINCEL SOLUTION FOR CONSTRUCTION AT STEEP SLOPING SITES

The steep sloping development sites usually offer the best views for marketability purposes, and they are commonly available at a reasonable price. The problems are accessibility, material handling and the cost of retaining walls which limits the development potential. The detail below is a cost and time effective solution for steep sloping sites with high retaining walls.

HOUSING ESTATES AT SLOPING SITES

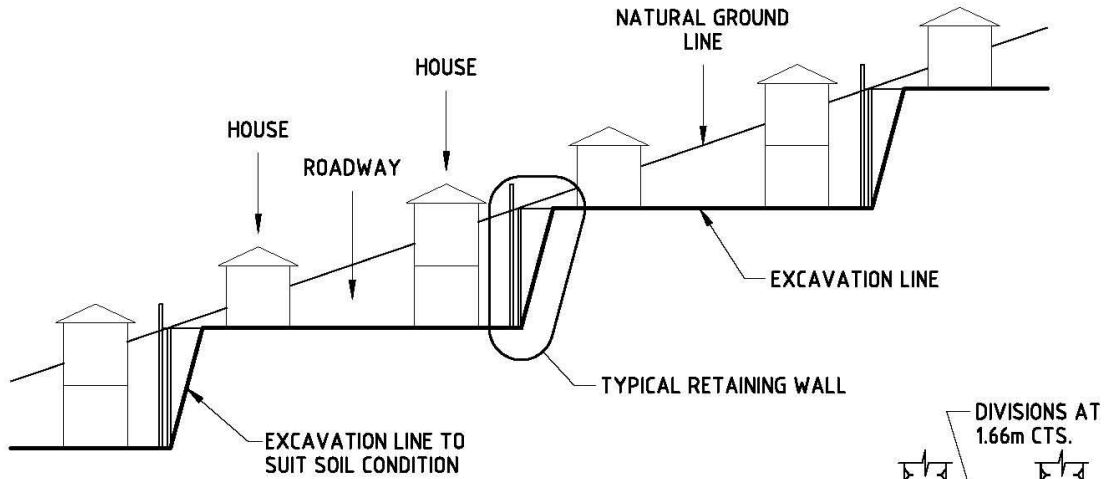

TYPICAL SLOPING SITE SECTION

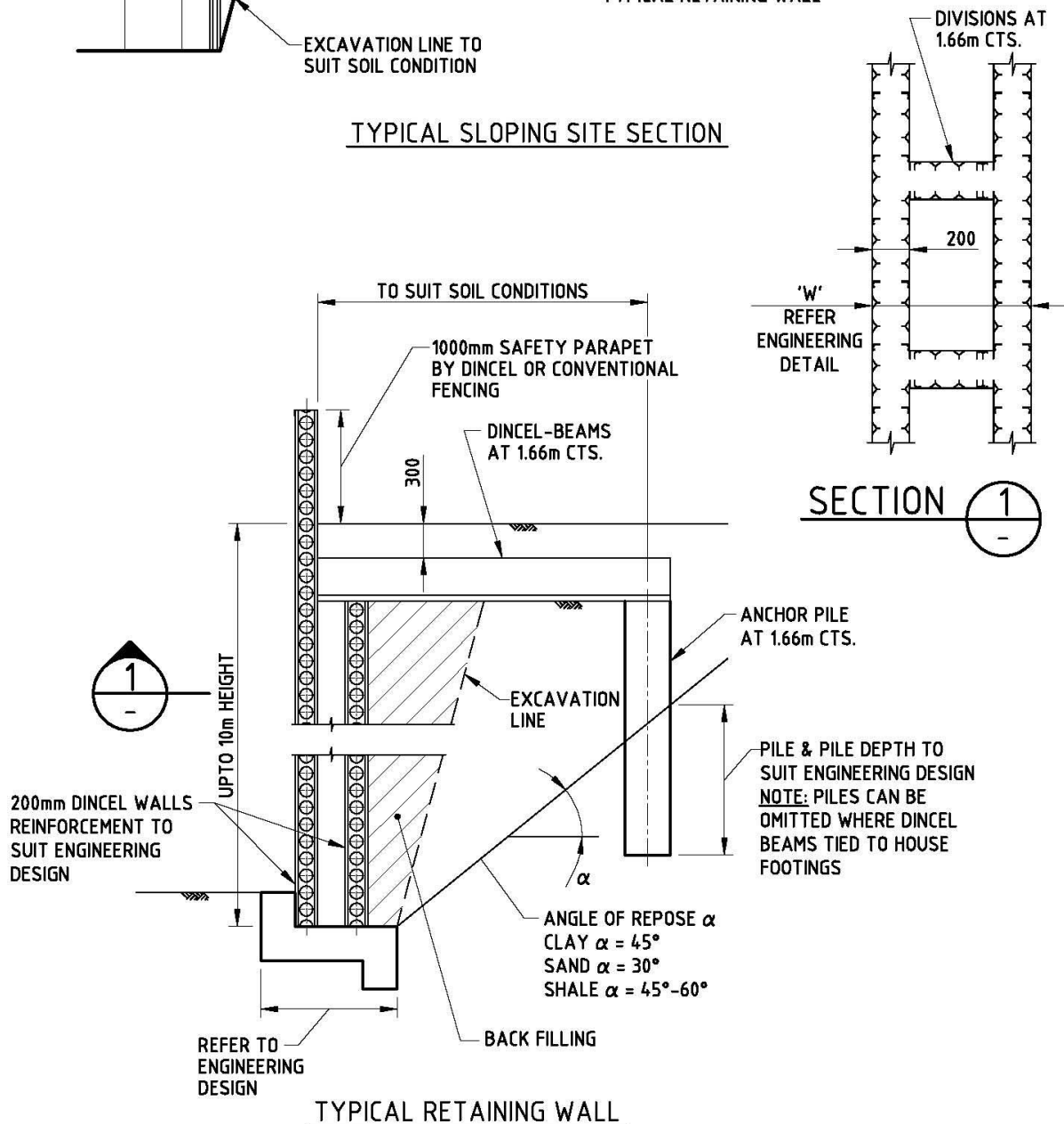

TYPICAL RETAINING WALL

DETAILING AT FOOTINGS BELOW GROUND LEVEL

Issues to be considered by the designer are:

- Soft/water logged soil excavation conditions may necessitate segmental basement wall construction as shown below. The builder may prefer to pour the slab-on-ground prior to the full completion of the basement perimeter wall (refer Detail N/2).
- Possibility or presence of water behind the retaining wall due to flash flooding, tidal or permanent water table.
- Waterproofing and termite treatment at footing and wall junction.
- If the builder wishes to minimise the footing excavation depths (refer Detail N/2).

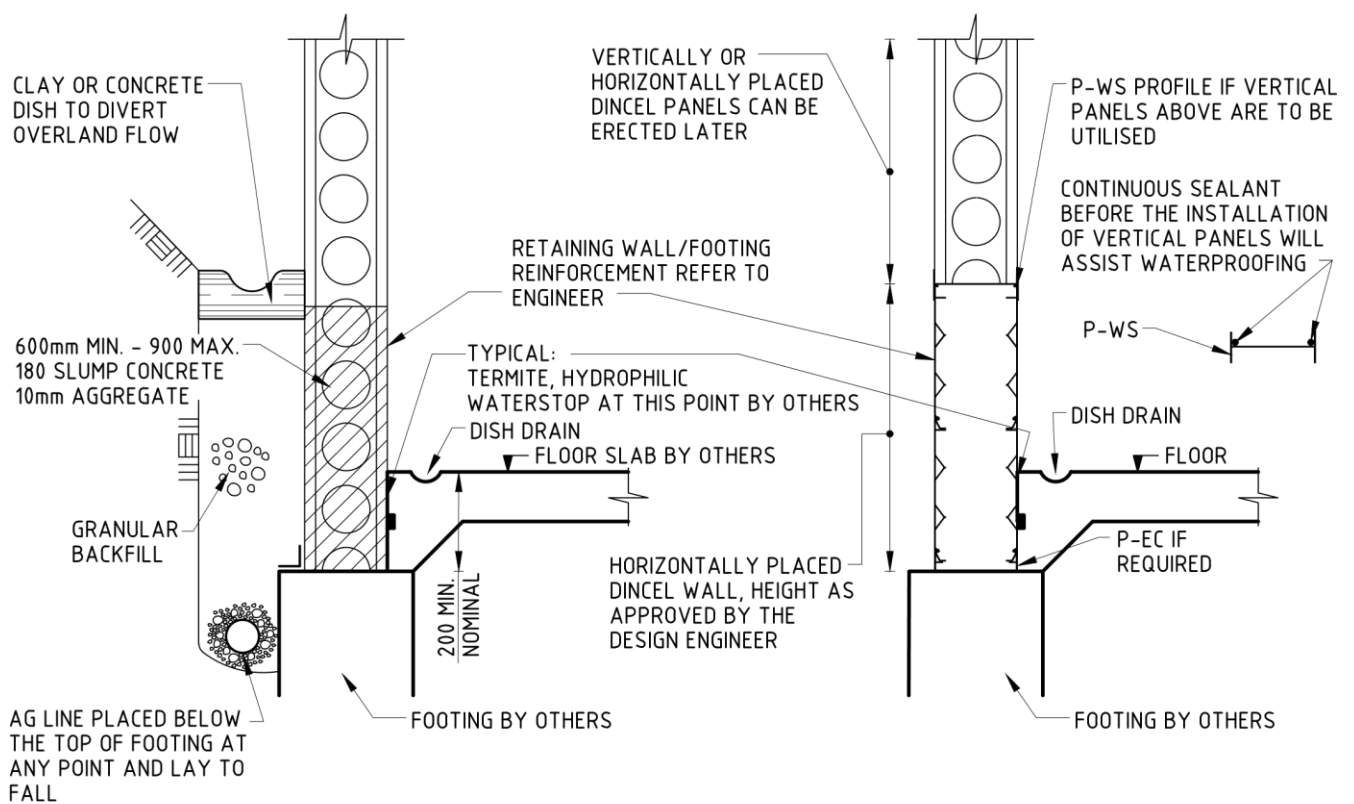

CONVENTIONAL VERTICALLY PLACED
DINCEL BASEMENT WALL

SEGMENTAL DINCEL BASEMENT WALL
REFER TO ADJACENT DETAIL FOR DRAINAGE

PERIMETER FOOTING OF A BASEMENT WALL ABOVE WATER TABLE FOR 155mm OR 200mm DINCEL WALLS

DETAIL N
1

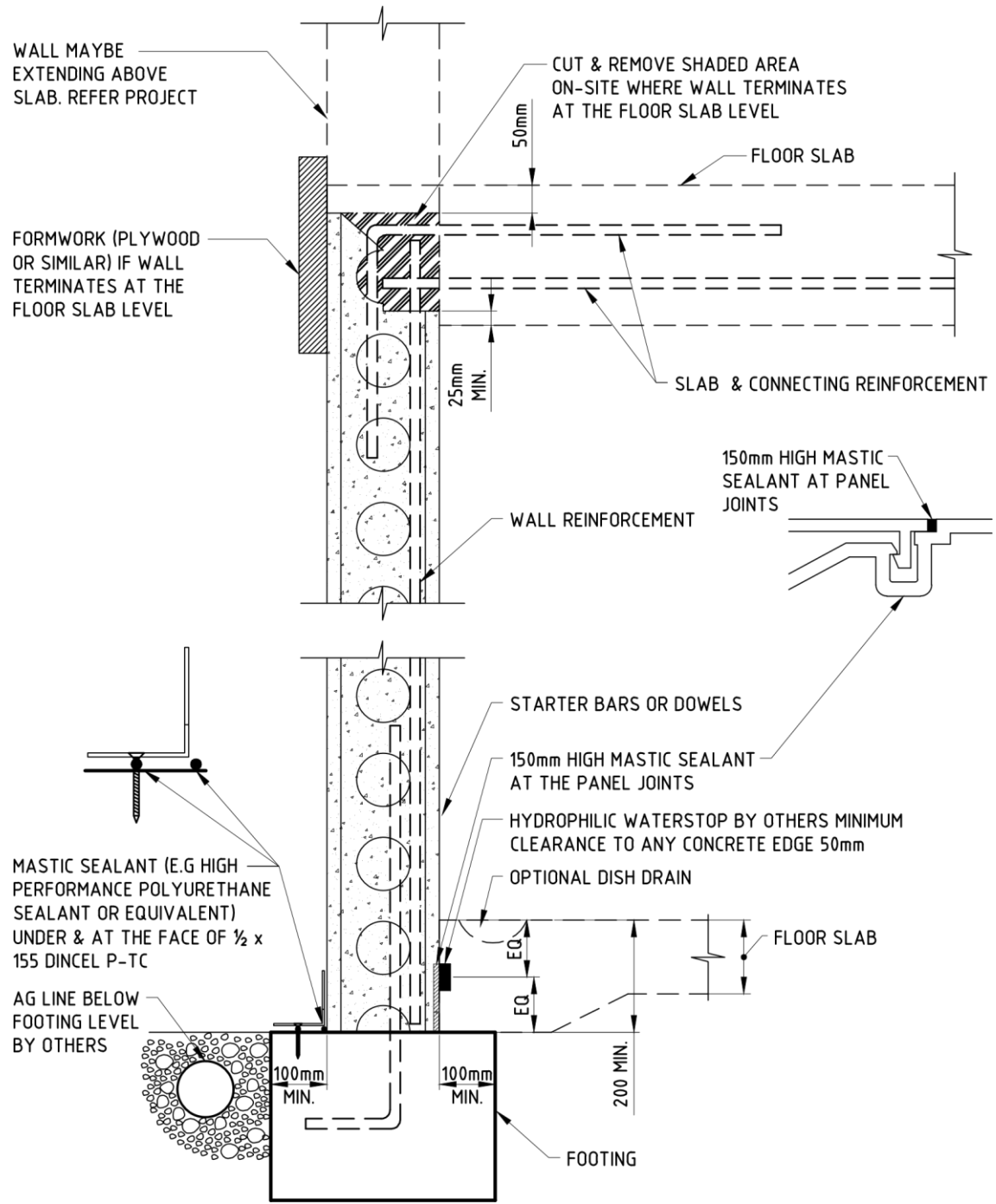

PERIMETER FOOTING OF A BASEMENT WALL
ABOVE WATER TABLE (IE. WET WALL)

DETAIL N
2

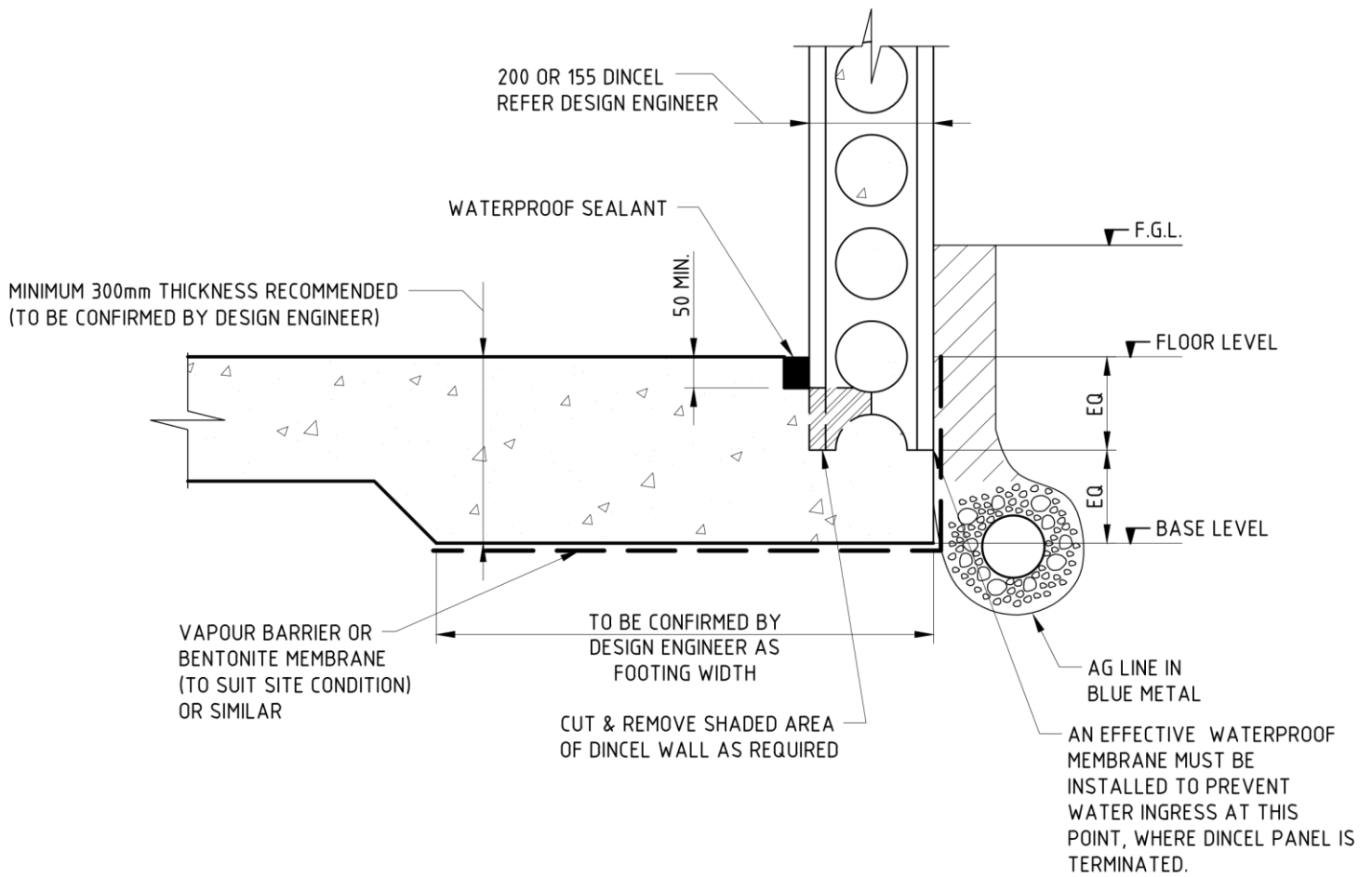

MONOLITHIC FOOTING / DINCEL WALL DETAIL

- THE ABOVE DETAIL IS NOT SUITABLE IF THE FLOOR SLAB IS BELOW THE PERMANENT WATER TABLE
- INTERNAL DISH DRAINS ARE RECOMMENDED IF AG LINES CANNOT BE RELIED UPON FOR UNUSUAL STORMWATER SURCHARGE OR PERMANENT/TEMPORARY WATER TABLE CONDITIONS. REFER TO DETAIL N/2
- THE WALL & SLAB SHOULD BE DESIGNED FOR HYDROSTATIC PRESSURE IN THE ABSENCE OF WATER PRESSURE RELEASE SUCH AS AG LINES OR NATURAL DRAINAGE
- IT IS THE DESIGN ENGINEERS RESPONSIBILITY TO DESIGN/WATERPROOF THE FLOOR SLAB

DETAIL N
3

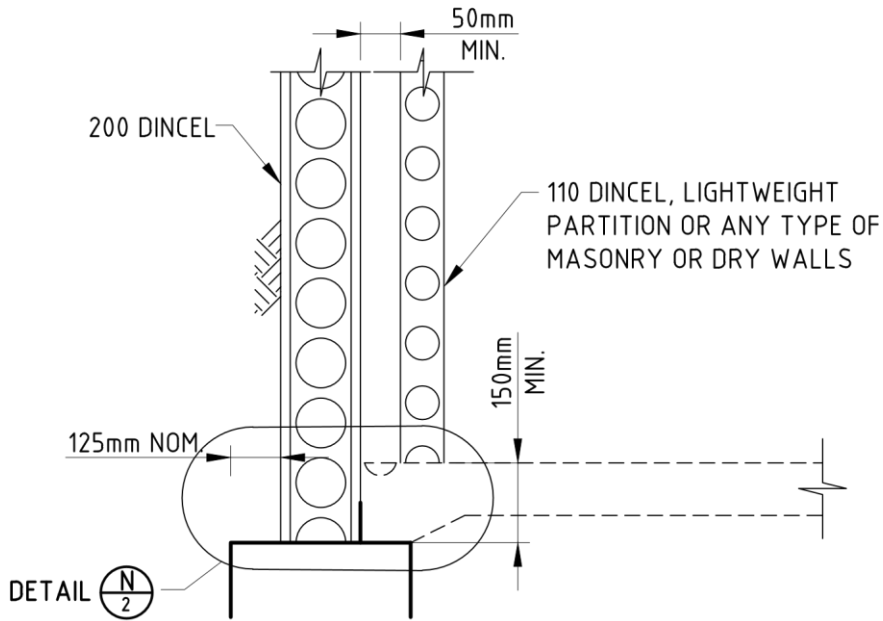

BELOW GROUND HABITABLE ROOM DETAIL

WATER TABLE BELOW FOOTING LEVEL

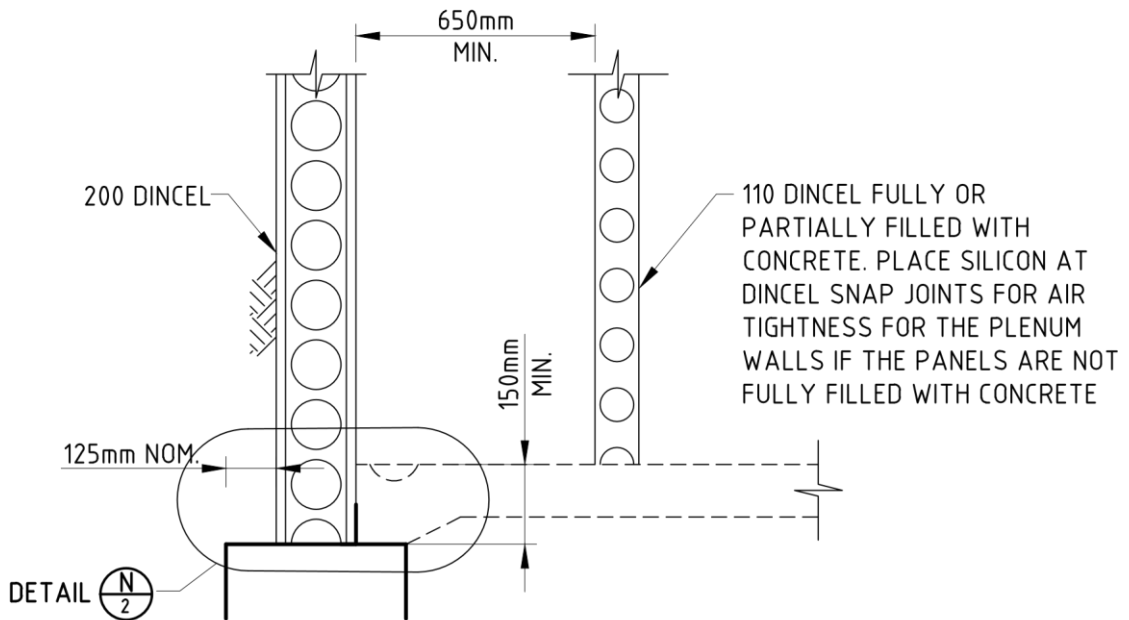

BELOW GROUND MECHANICAL PLENUM DETAIL

WATER TABLE BELOW FOOTING LEVEL



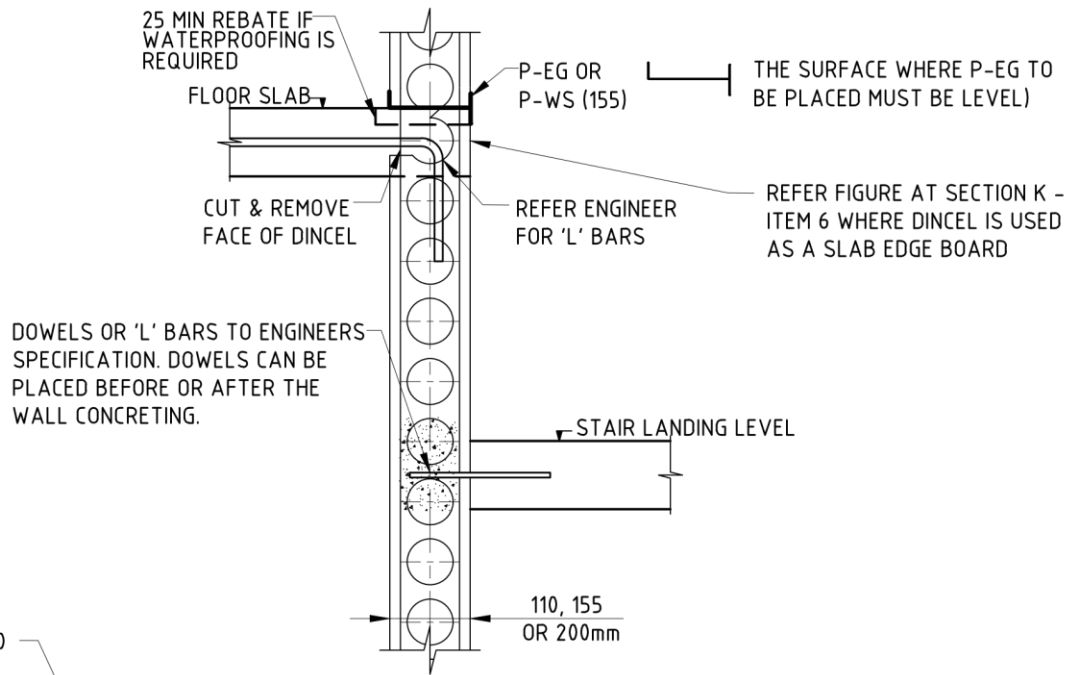

SECTION AT STAIR WALL

REFER ENGINEER FOR WALL REINFORCEMENT
REFER DETAIL S IF WALLS ARE USED AS SHEARWALLS

NOMINAL N12 AT 1000
DOWELS DRILLED
IN FLOOR SLAB. REFER
ENGINEERING DESIGN

THE USE OF P-G OR P-EG
TO HOLD THE BOTTOM OF
THE WALLS DURING
INSTALLATION IS SUBJECT
TO DESIGN ENGINEERS
APPROVAL (IE. REDUCTION
IN BEARING CAPACITY) AND
RECOMMENDED ONLY WHEN
DRILLED STARTER BARS
ARE USED

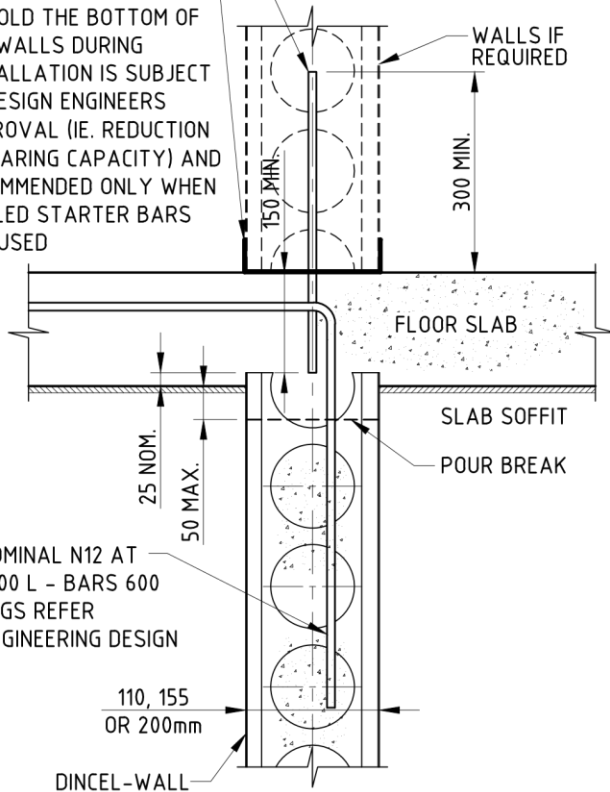

INTERNAL WALL ALTERNATIVE DETAIL 1

• THE SURFACE WHERE P-G TO BE PLACED MUST BE LEVEL

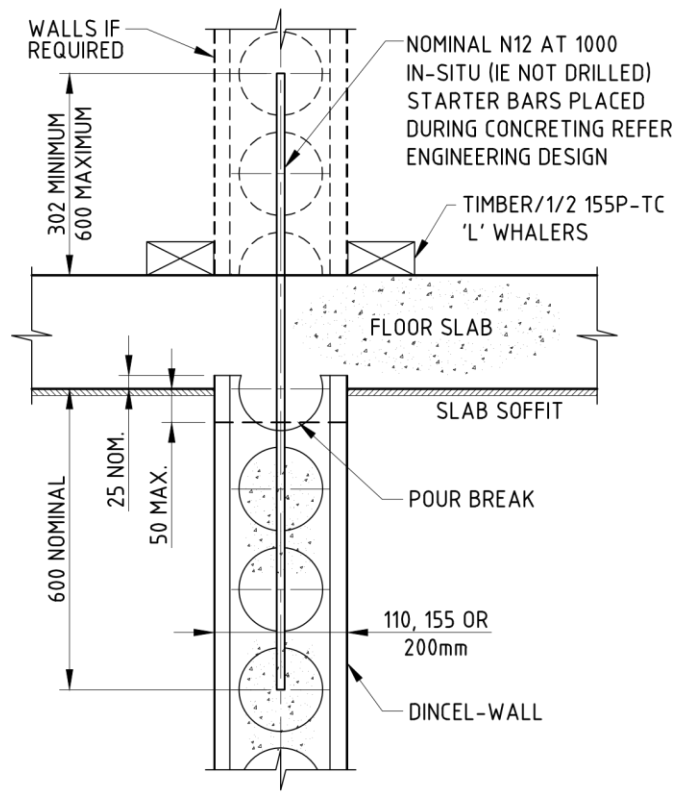

INTERNAL WALL ALTERNATIVE DETAIL 2

• USE TIMBER WHALERS (PG NOT ALLOWED) AS THE FINISH
SLAB SURFACE CANNOT BE LEVEL DUE TO THE PRESENCE
OF IN-SITU STARTER BARS
• SLAB REINFORCEMENT NOT SHOWN FOR CLARITY

DETAIL 0

FACADE WALL/SLAB EDGE DETAILS

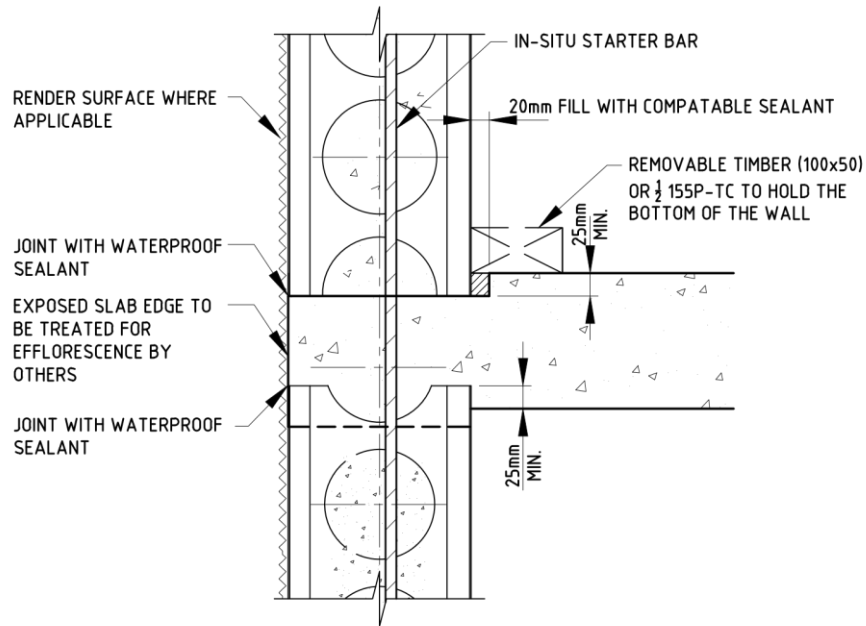

ALTERNATIVE SLAB EDGE DETAIL WITH IN-SITU STARTER BAR

- NO P-G OR P-EG PROFILES ALLOWED IF IN-SITU STARTER BARS ARE USED (IE NOT POSSIBLE TO ACHIEVE FLAT/FLUSH SURFACE UNDER THE PROFILES)
- IF EXTERNAL, POLYMER SKIN IS CONTINUED FOR ANY REASON, REFER TO RELEVANT NOTES IN THE RECOMMENDED SLAB EDGE DETAIL WITH DRILLED STARTER BARS
- EDGE REBATE MAYBE OMITTED WHEN WATERPROOFING IS NOT REQUIRED

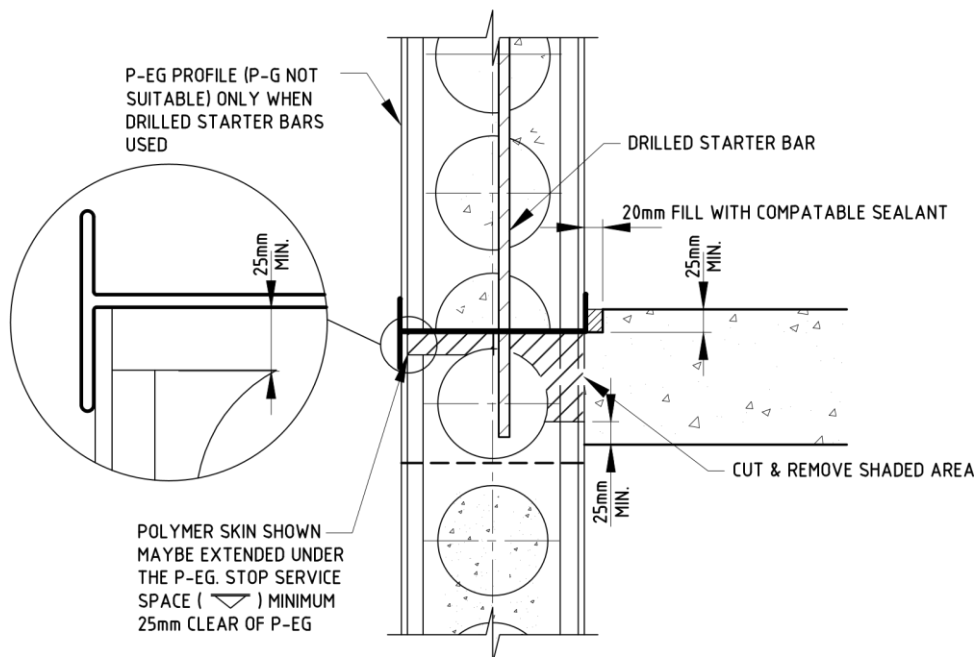

RECOMMENDED SLAB EDGE DETAIL WITH DRILLED STARTER BAR

- DETAIL ONLY APPLICABLE WHEN DRILLED STARTER BARS ARE USED
- IF THIS DETAIL IS ADOPTED INSTALLER MUST PROP THE EXTERNAL POLYMER FACE TO ACHIEVE STRAIGHT EDGE WITHOUT IRREGULARITIES WHICH MUST ALIGN WITH THE WALL ABOVE
- EDGE REBATE MAYBE OMITTED WHEN WATERPROOFING IS NOT REQUIRED
- IF THE FACE OF P-EG IS REMOVED FOR RENDER FINISH PURPOSES THEN THE JOINT BETWEEN WALLS MUST HAVE WATERPROOF SEALANT

DETAIL P
1

FACADE WALL/SLAB EDGE DETAILS

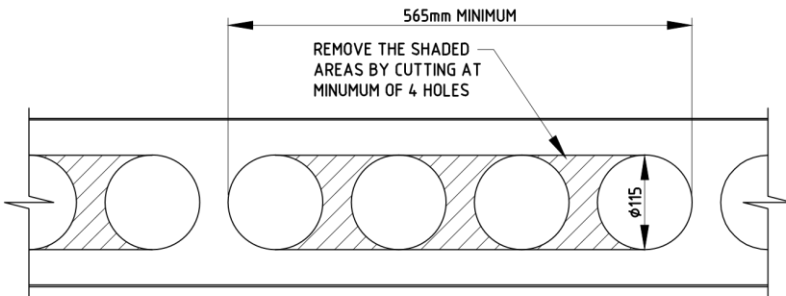
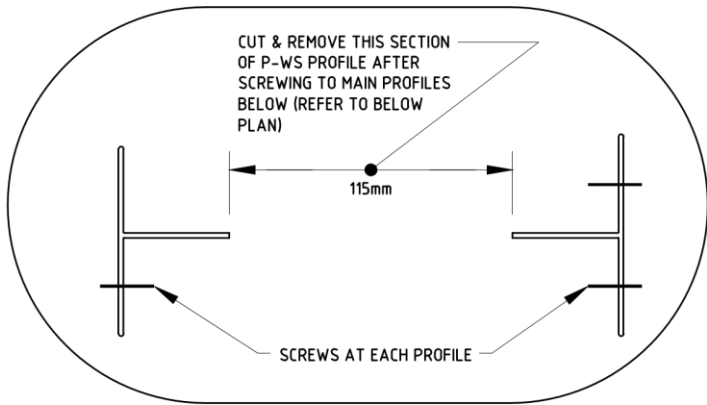

P-WS PLAN DETAIL

ALTERNATIVELY USE PLYWOOD INSTEAD OF P-WS

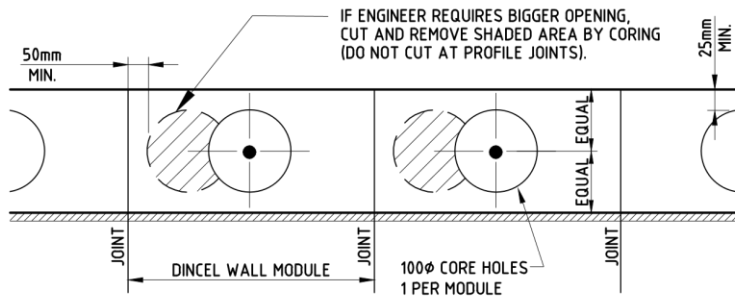

ELEVATION - 1 FOR 155 & 200 DINCEL

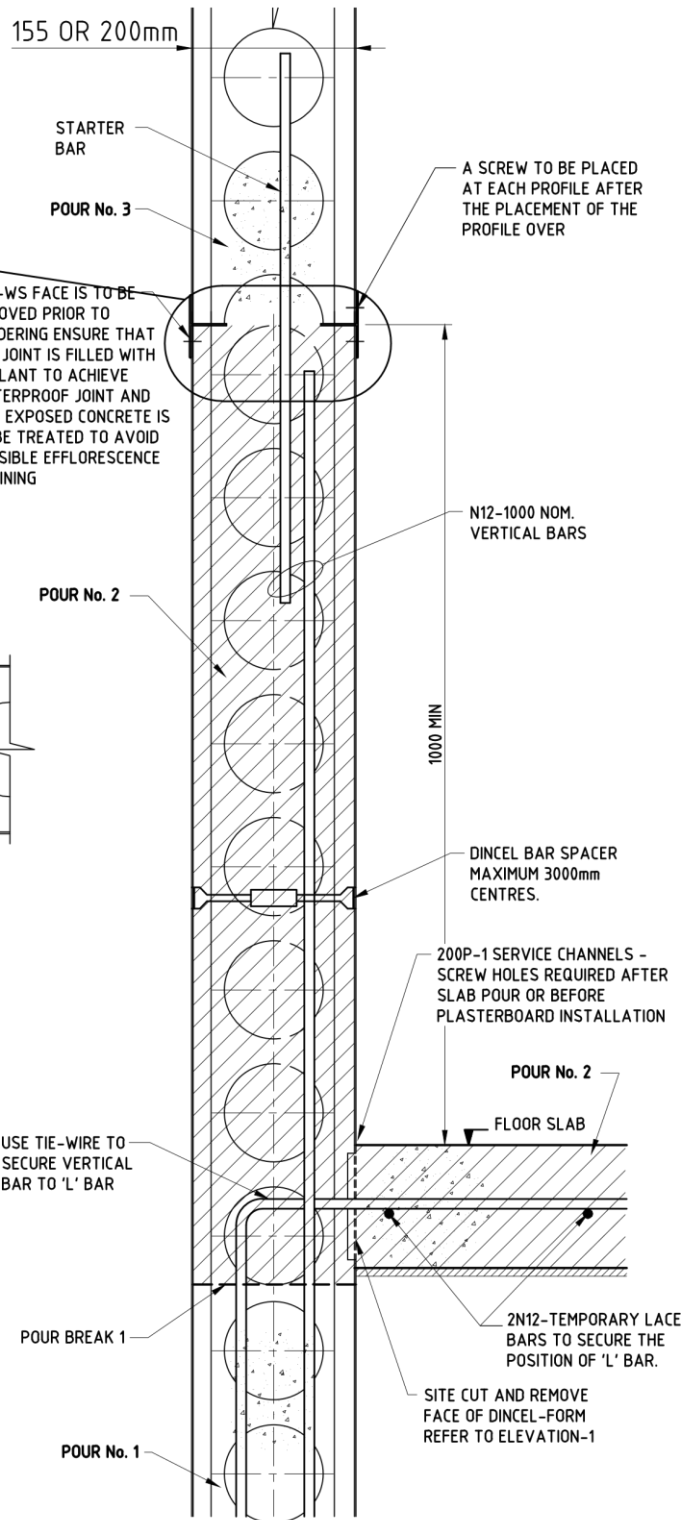

WALL EXTENDED TO WINDOW SILL-LEVEL

FACADE WALL CONSTRUCTION WITHOUT SCAFFOLDING

DETAIL P
2

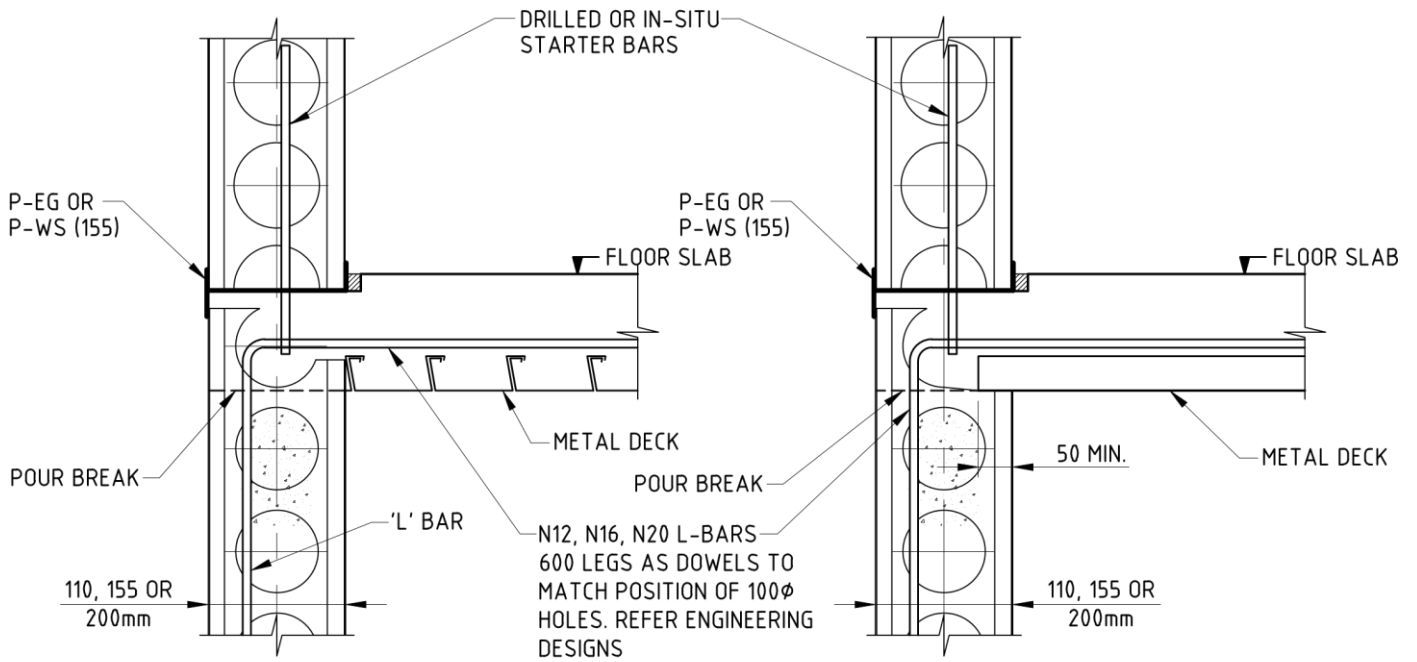

ALTERNATIVE DETAIL -1
EXTERNAL WALL

ALTERNATIVE DETAIL -2
EXTERNAL WALL

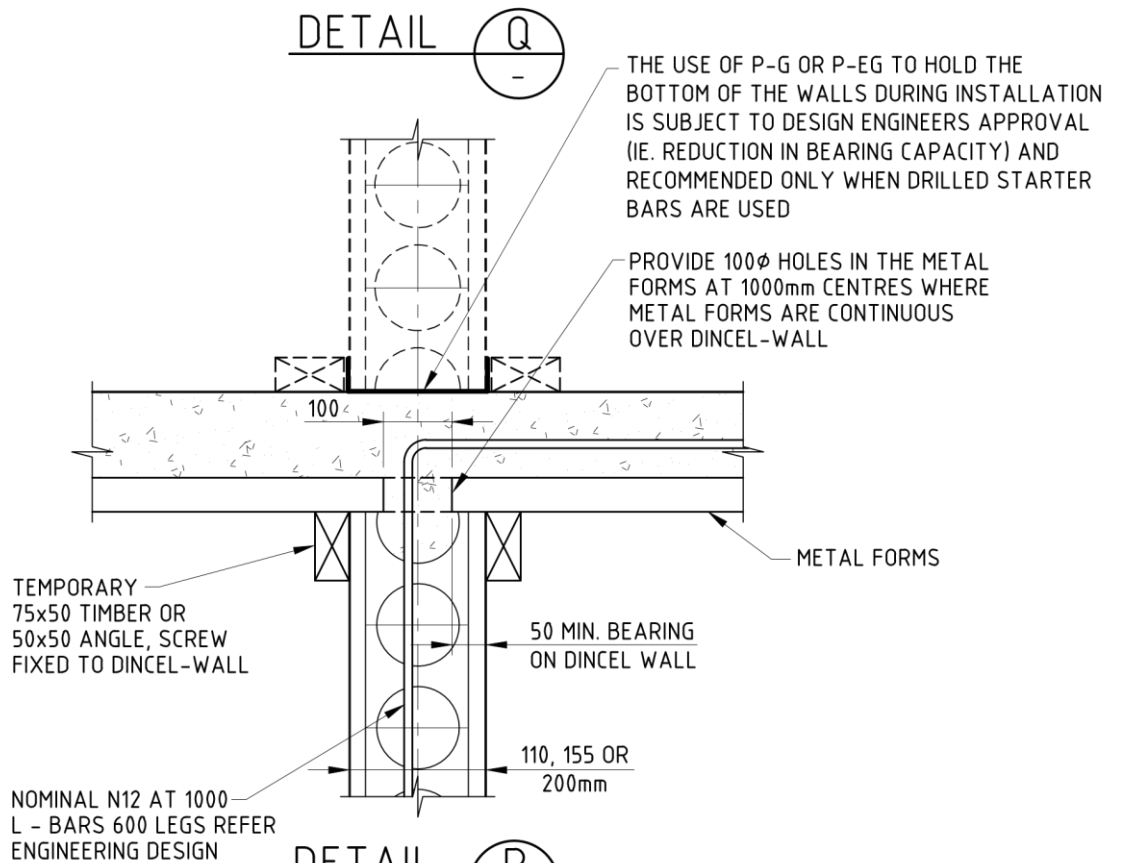

DETAIL R

DETAILS FOR METAL FORM

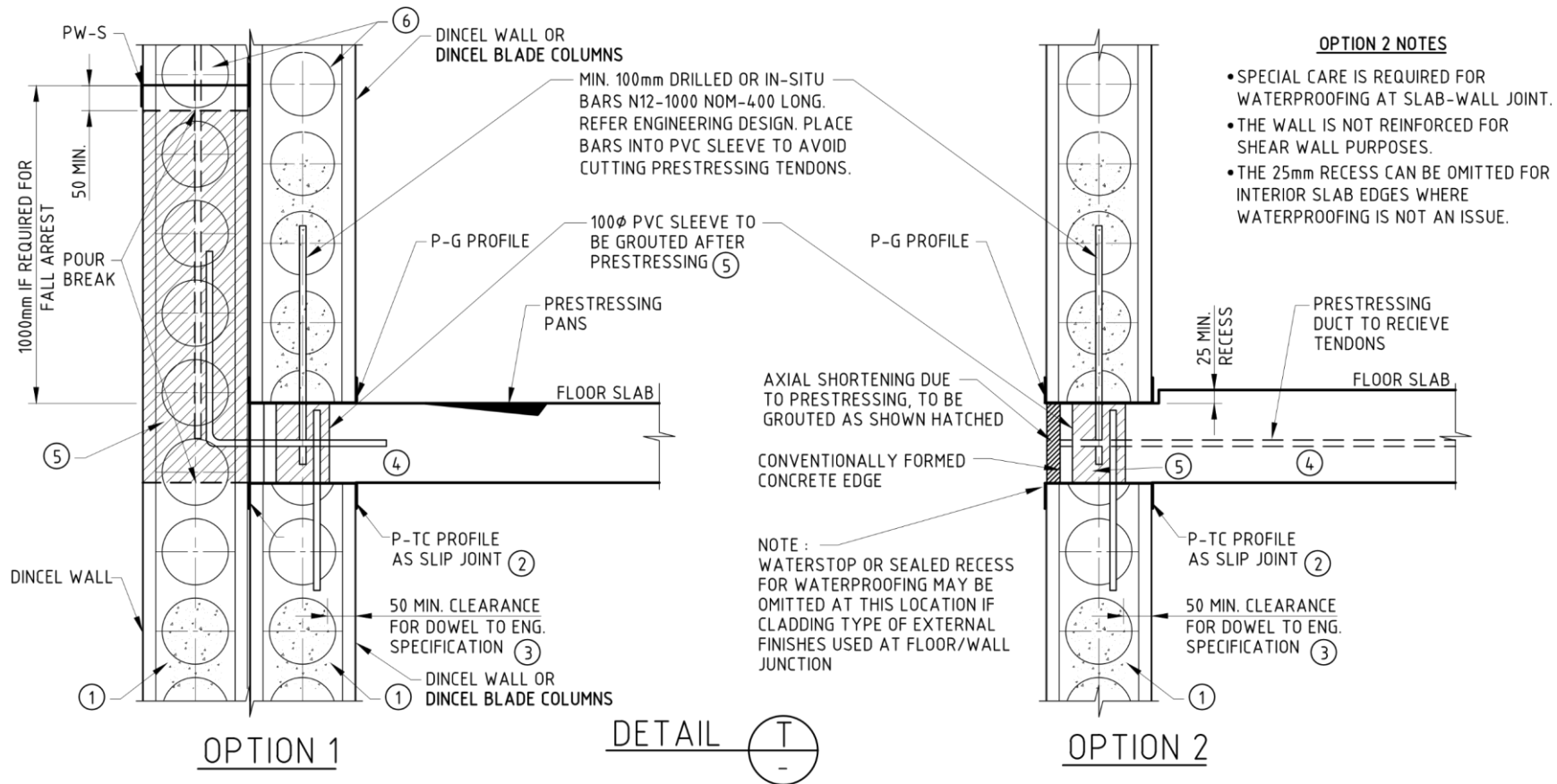

SLAB EDGE POST TENSIONING AND SLIP JOINT DETAIL

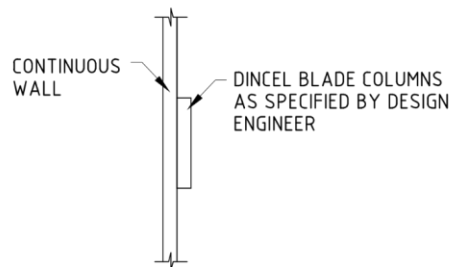

PLAN AT OPTION 1

- ① - POUR WALL/BLADE COLUMN CONCRETE
- ② - PLACE P-TC AS SLIP JOINT
- ③ - PLACE DOWELS & L BARS (BY DESIGN ENGINEER)
- ④ - POUR AND STRESS THE FLOOR SLAB
- ⑤ - GROUT DOWELLED JOINT & CONCRETE THE EXTERNAL DINCEL WALL UP TO PW-S
- ⑥ - POUR CONCRETE TO WALL/BLADE COLUMN OVER

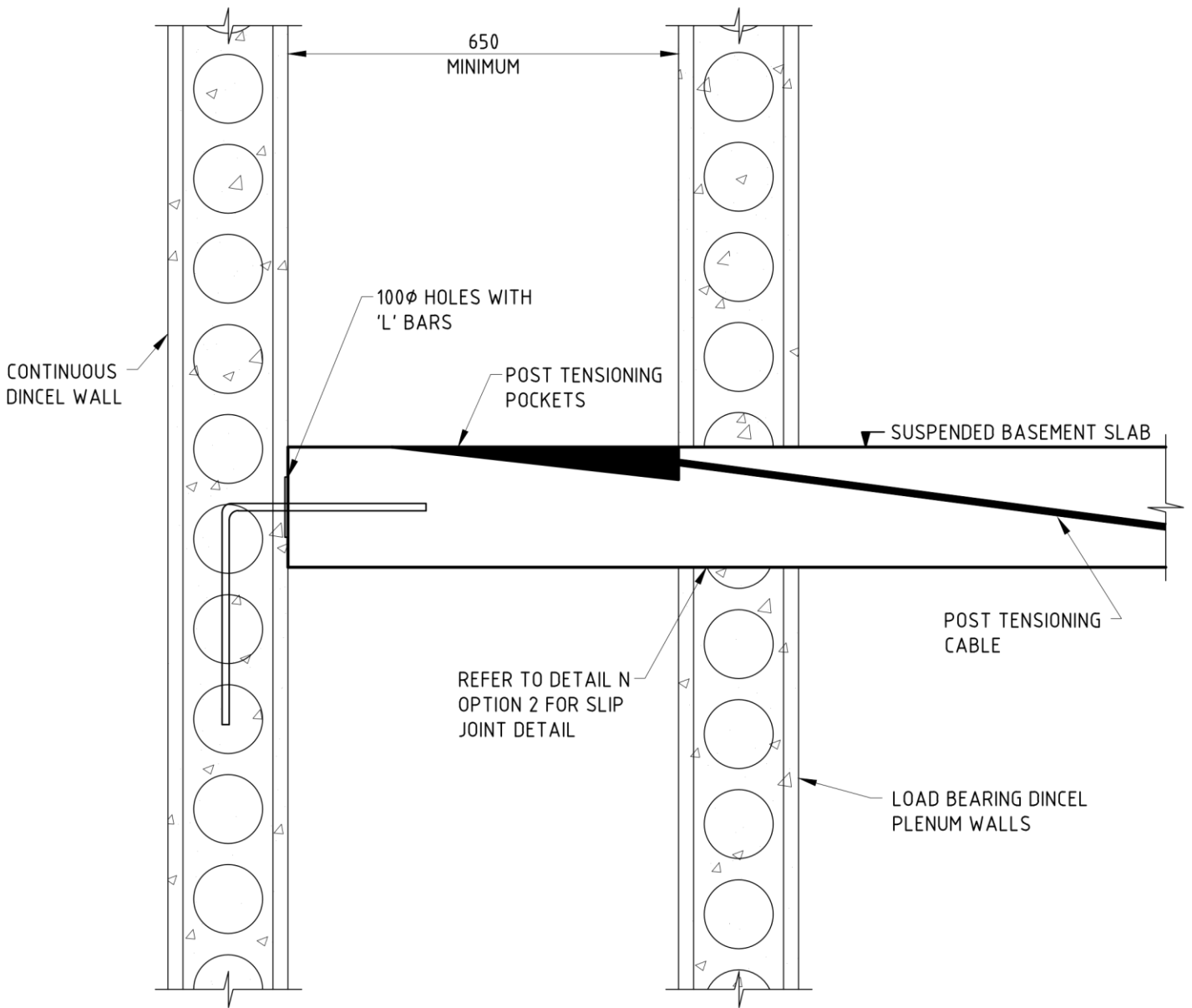

POST TENSIONING DETAIL AT BASEMENT SLABS

DETAIL (U)

SWIMMING POOLS

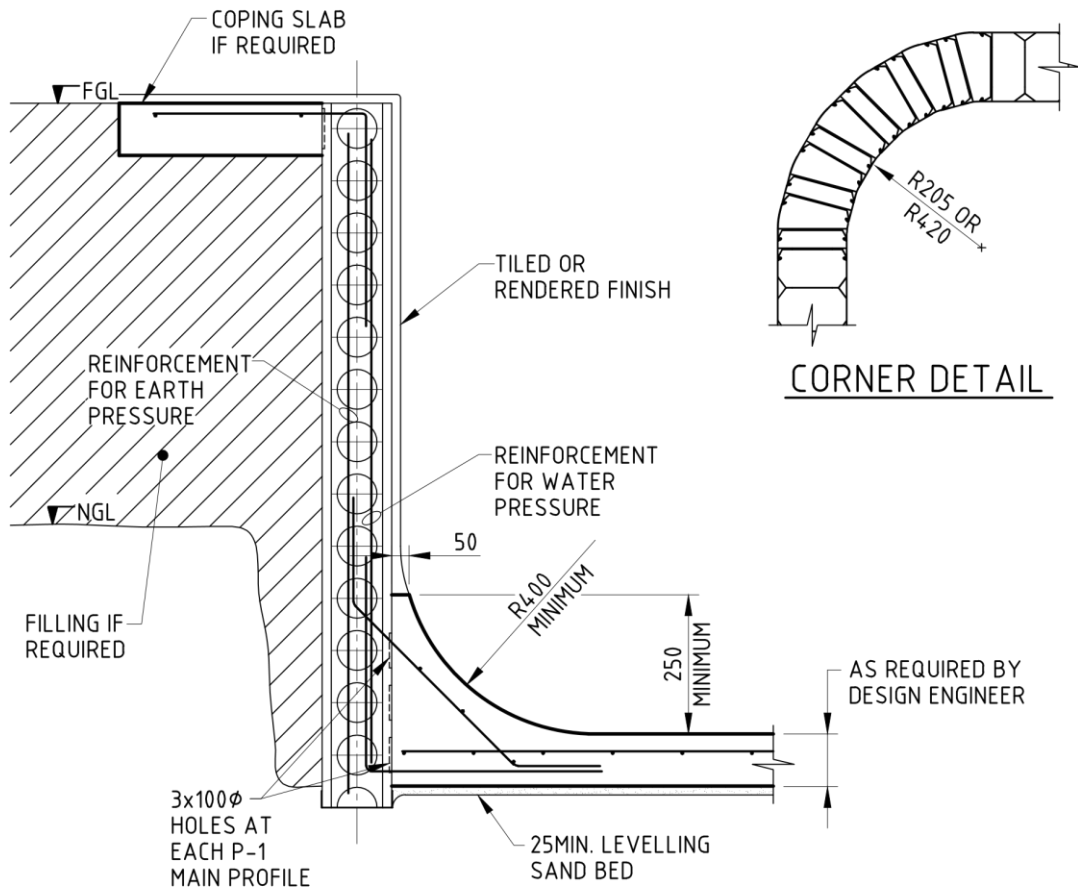

SWIMMING POOL WALL DETAIL

REFER STRUCTURAL ENGINEERING DESIGN
FOR STEEL REINFORCEMENT

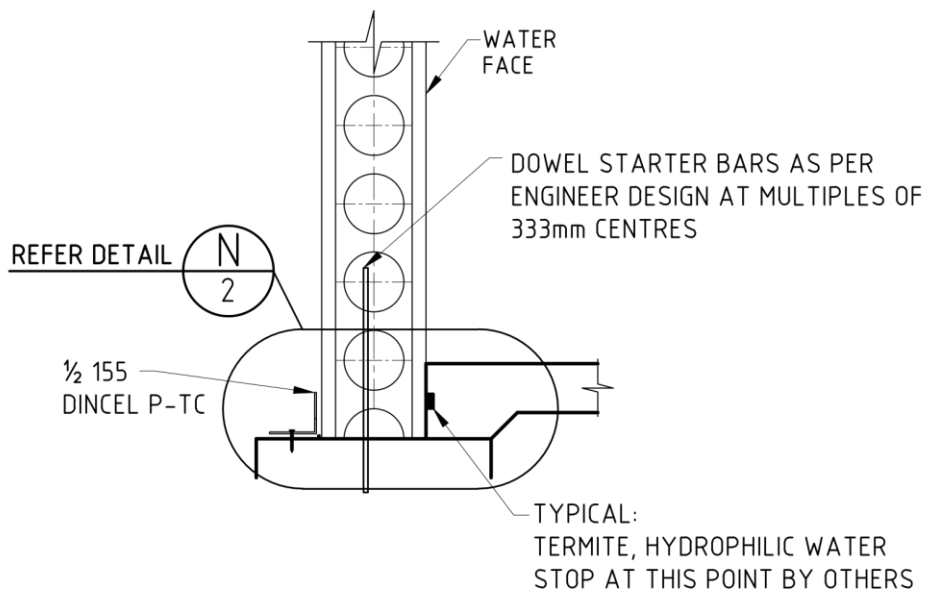

ALTERNATIVE DETAILS AT THE POOL BASE

REINFORCEMENT TO SUIT STRUCTURAL
ENGINEERING DESIGN REQUIREMENTS

LIQUID STORAGE TANKS

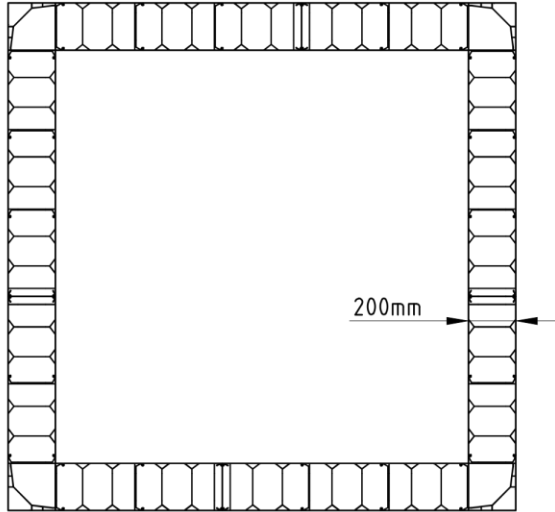

RECTANGULAR OR
SQUARE TANK

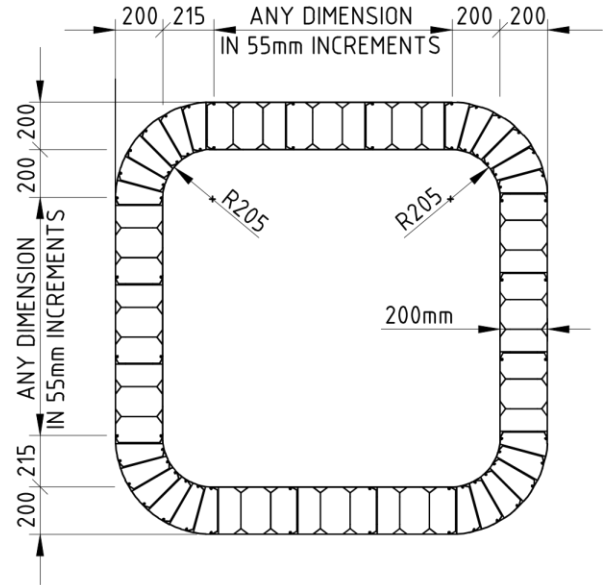

RECTANGULAR OR
SQUARE TANK

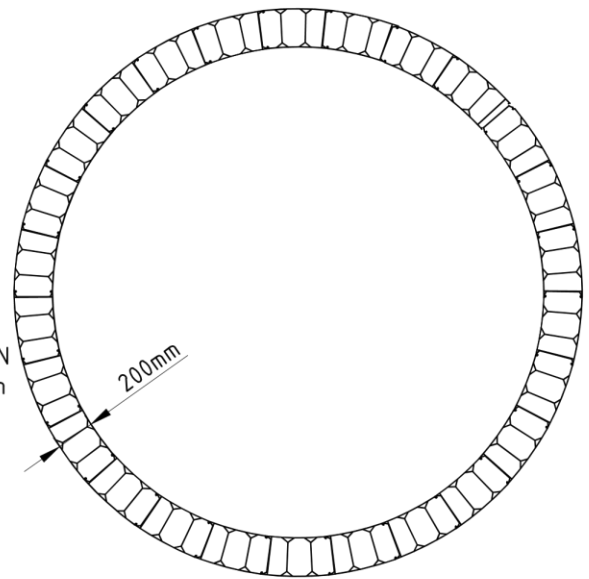
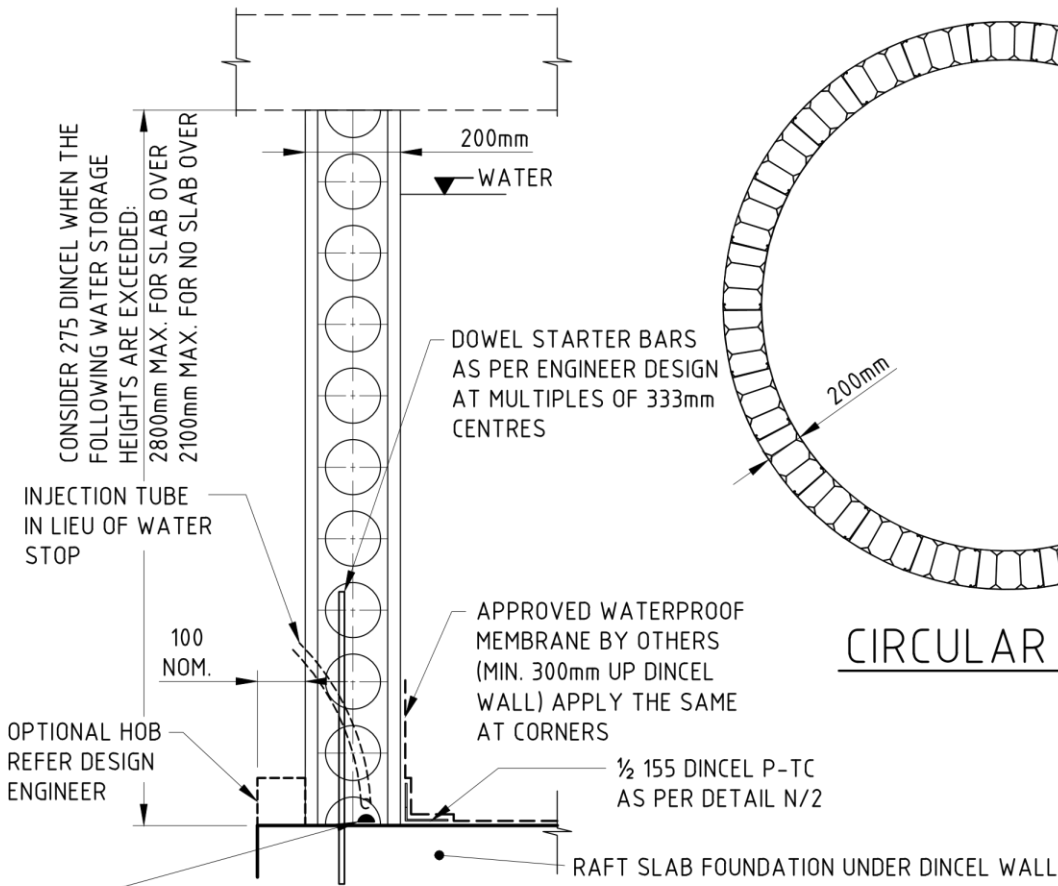

CIRCULAR TANK

HYDROPHILIC WATER STOP MAY BE CONSIDERED IN LIEU OF INJECTION TUBES. THE USE OF HYDROPHILIC WATER STOPS ARE WORKMANSHIP DEPENDENT IE. SLUMP/AIR VOID FREE NATURE OF CONCRETE FILLING, IMPERFECTION OF PREPARED CONCRETE SURFACE TO RECEIVE WATER STOPS, LAPPING/BUTTING OF WATER STOPS AT PARTICULARLY CORNERS, TIME OF PLACEMENT, TIME OF CONCRETE FILLING ETC. MAY MAKE HYDROPHILIC WATER STOPS INEFFECTIVE FOR THE PERFECT END RESULT

SECTION AT TANK WALL

REINFORCEMENT TO SUIT STRUCTURAL ENGINEERING DESIGN REQUIREMENTS

PITS

FOR: STORMWATER, POTABLE WATER, WASTE WATER & SEWAGE

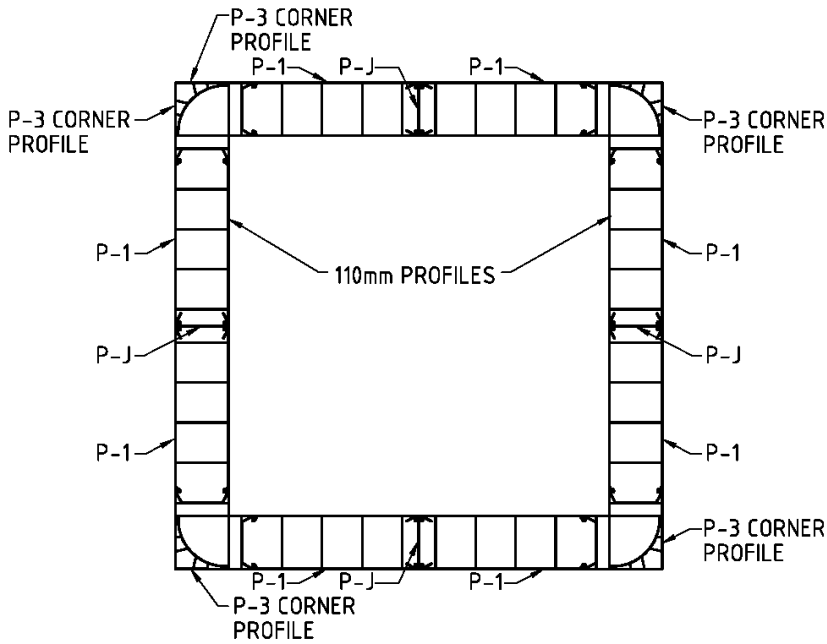

INTERNAL PIT DIMENSIONS

- 450x450
- 800x800
- 1100x1100
- 1450x1450

CHANNELS

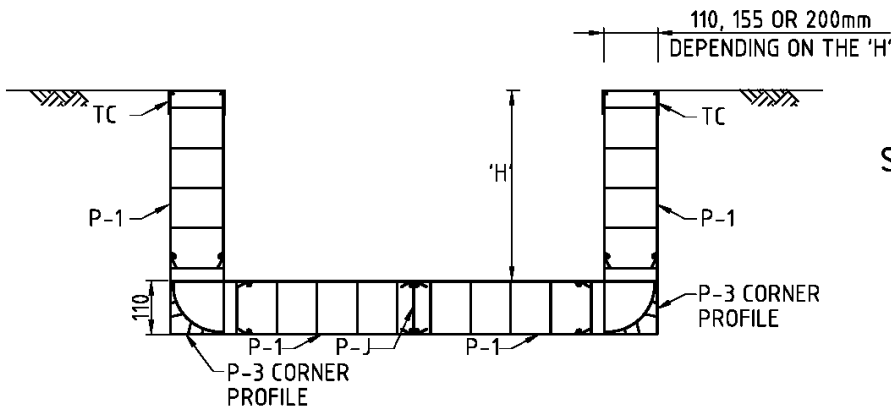

STORMWATER, IRRIGATION

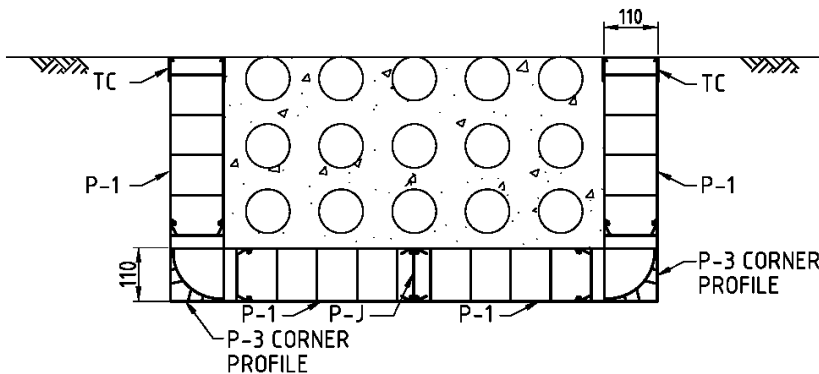

MINING/CABLE TRENCH

LIFT OR STAIR WALLS 155 OR 200 DINCEL AS SHEAR WALLS - HOOK BARS

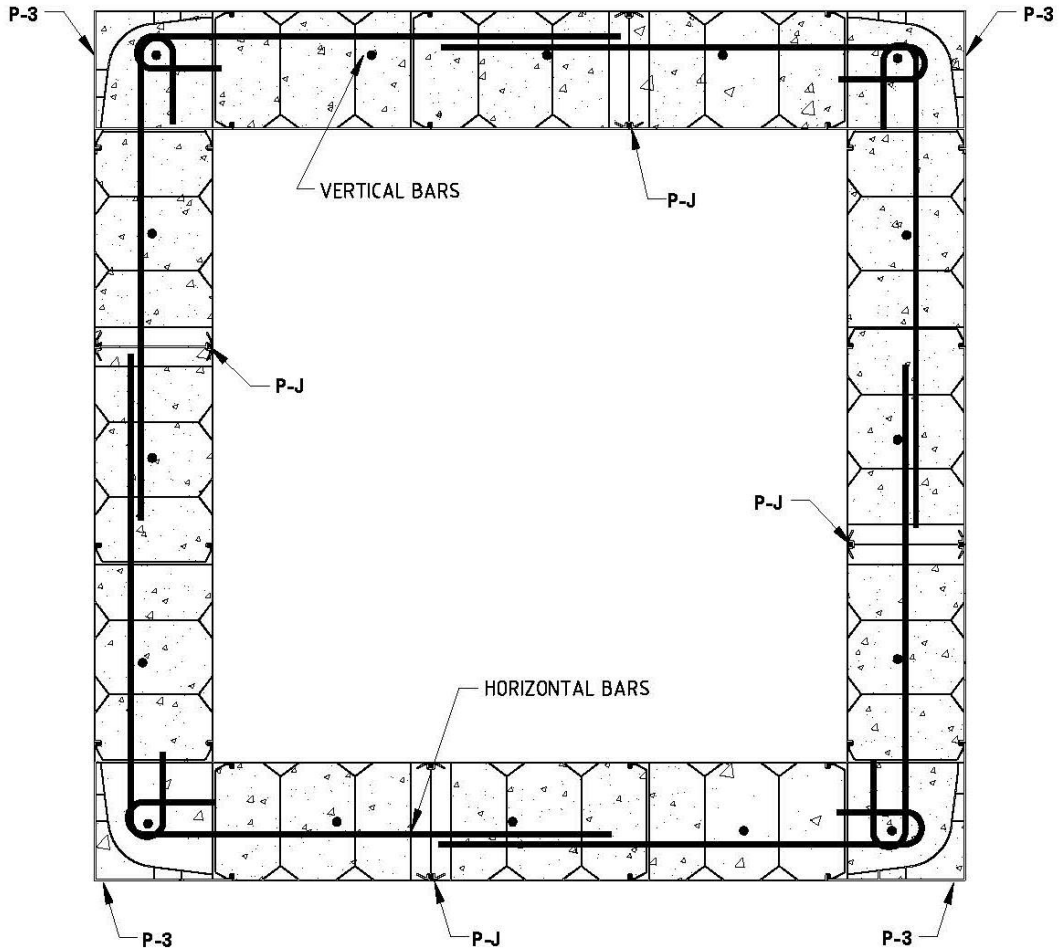

**FOR P-3 REFER CORNER
HOOK BAR INSTALLATION
DETAIL ON FOLLOWING PAGE**

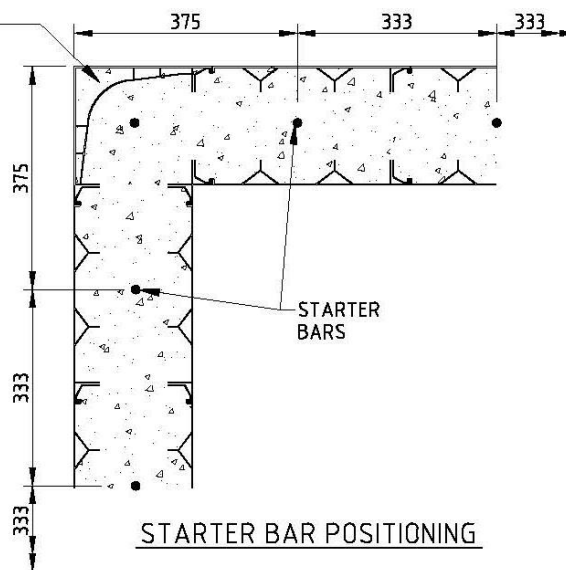

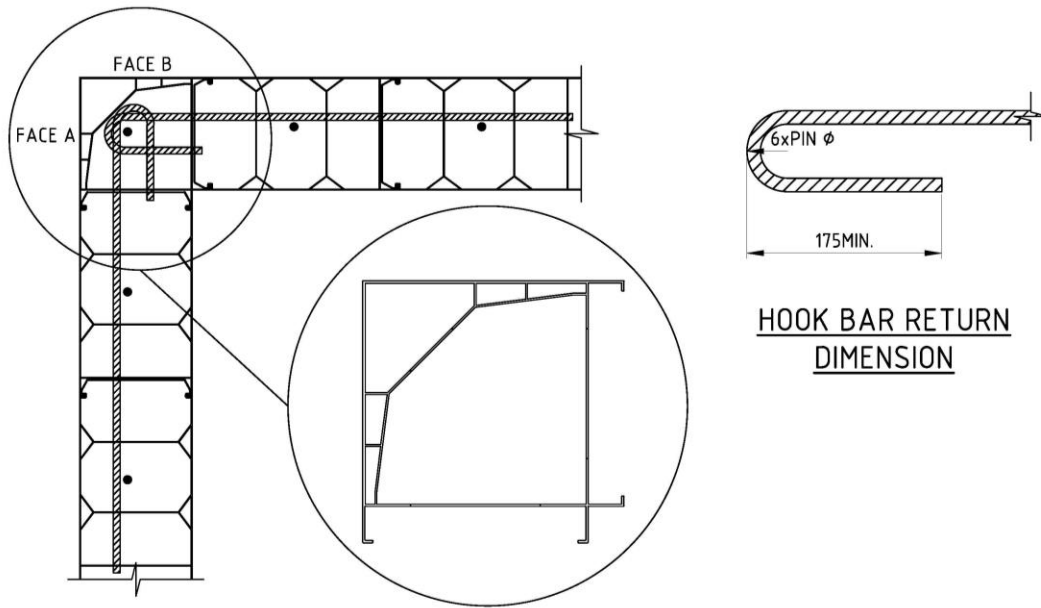

HOOK BAR DETAIL

- SINGLE OR DUAL 12 ϕ OR 16 ϕ HOOK BARS AT 150, 300 OR 450mm CTRS (REFER TO DESIGN ENGINEER)
- SUITABLE FOR CASES WHERE FACES A & B ARE NOT ACCESSIBLE (e.g BASEMENT WALL CORNERS AGAINST EXCAVATION)

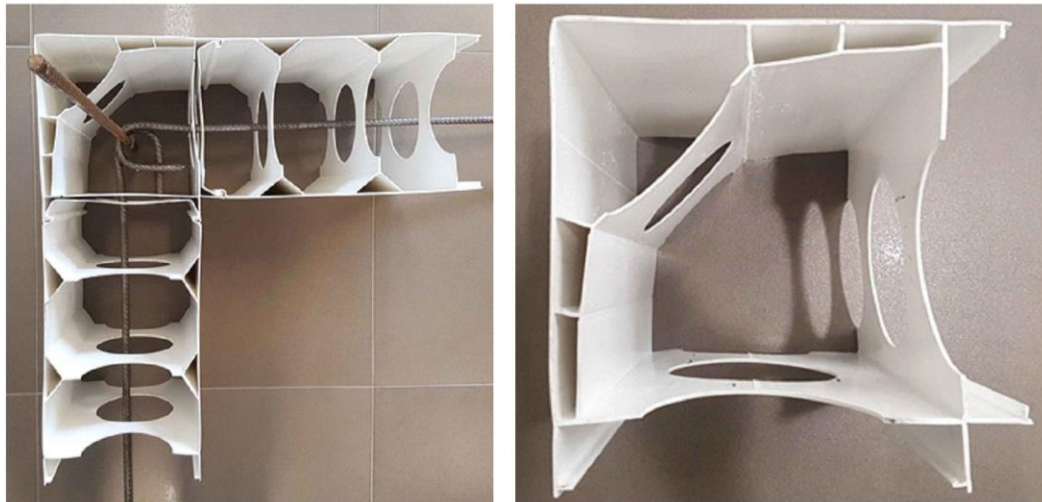

CORNER HOOK BAR INSTALLATION DETAILS FOR 110, 155 & 200 DINCEL PROFILES

LIFT OR STAIR WALLS 155 OR 200 DINCEL AS SHEAR WALLS - HAIR PIN BARS

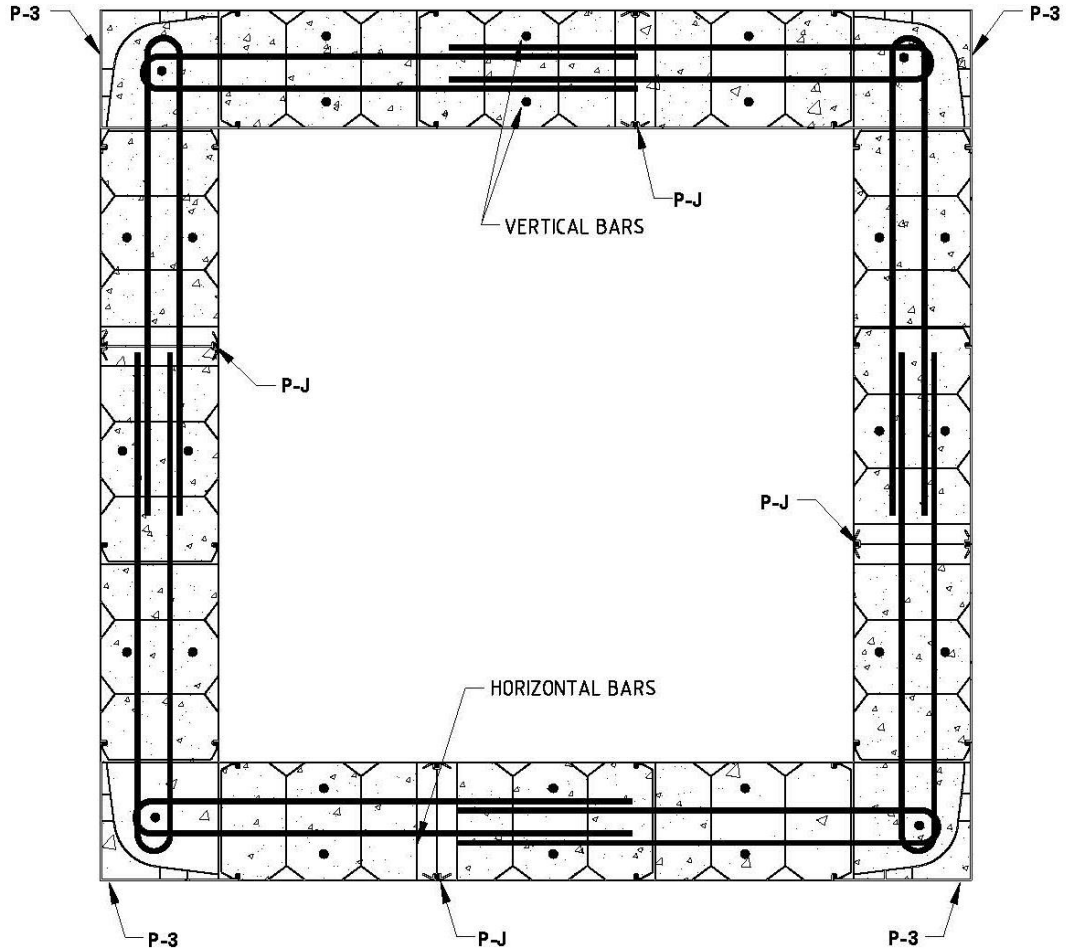

**FOR P-3 REFER CORNER
HAIR PIN INSTALLATION
DETAIL ON FOLLOWING PAGE**

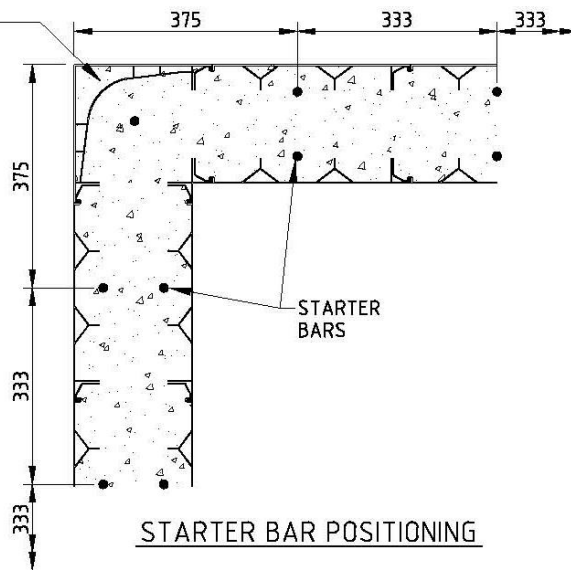

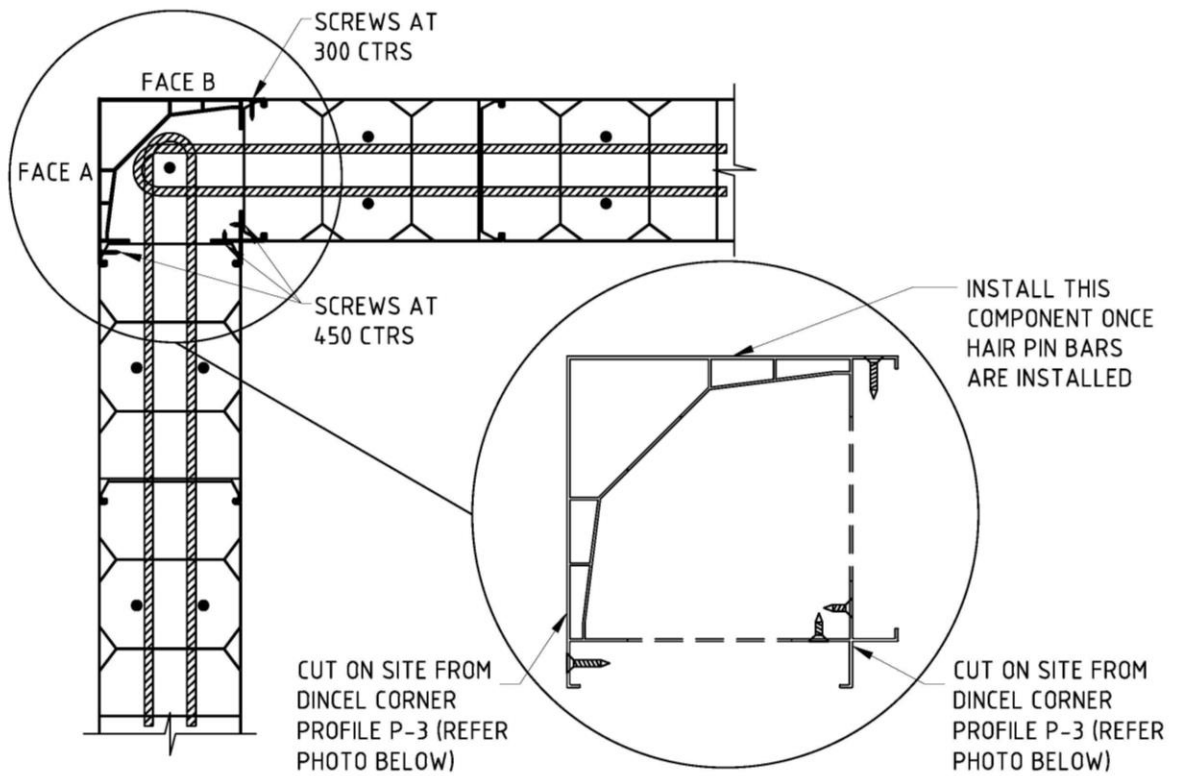

HAIRPIN 'U' BAR DETAIL

- SINGLE OR DUAL 12 ϕ OR 16 ϕ HAIR PIN BARS AT 150, 300 OR 450mm CTRS (REFER TO DESIGN ENGINEER)
- SUITABLE FOR CASES WHERE ACCESS AT FACES A & B IS ACCESSIBLE. (e.g LIFT, STAIR SHAFT CORNERS)
- ENGINEER REQUIRES REINFORCEMENT BARS ON BOTH FACES

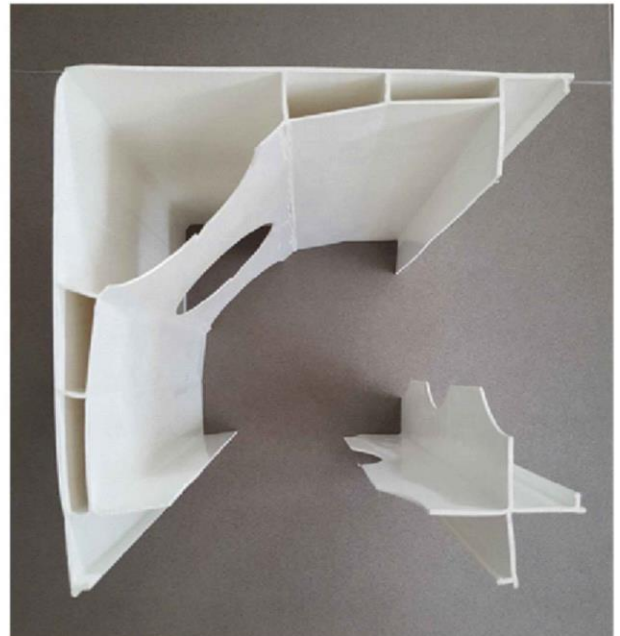

CORNER HAIR PIN BAR INSTALLATION DETAILS FOR 155 & 200 DINCEL PROFILES

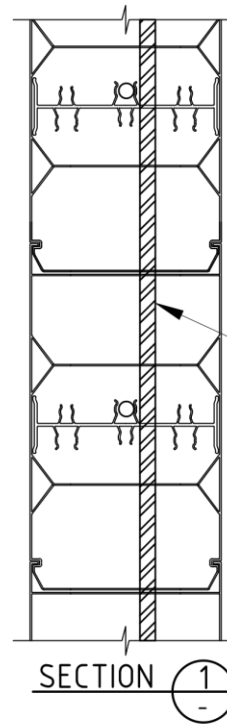
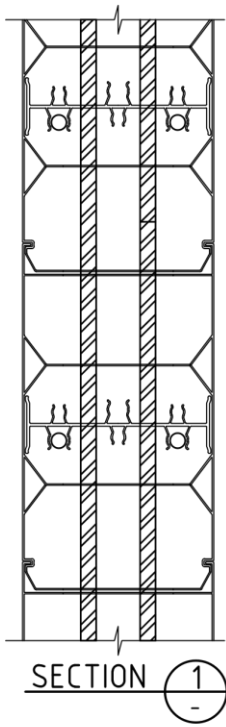

HORIZ. BARS CAN BE OMITTED FOR NON-SHEAR WALLS

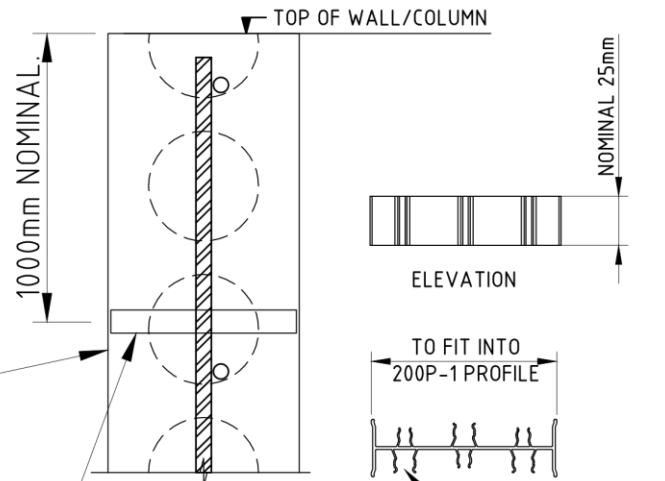
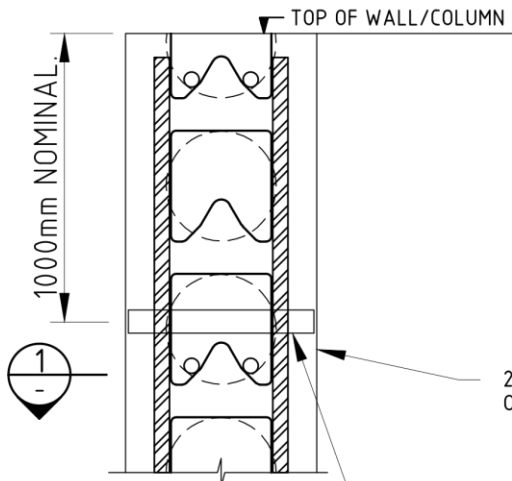

DINCEL 200P-VRC ACCOMODATES:

- ACCOMODATE MAJORITY BAR SIZES
- MINIMUM 2x200P-VRC RECOMMENDED AS SHOWN (PER VERTICAL BAR)

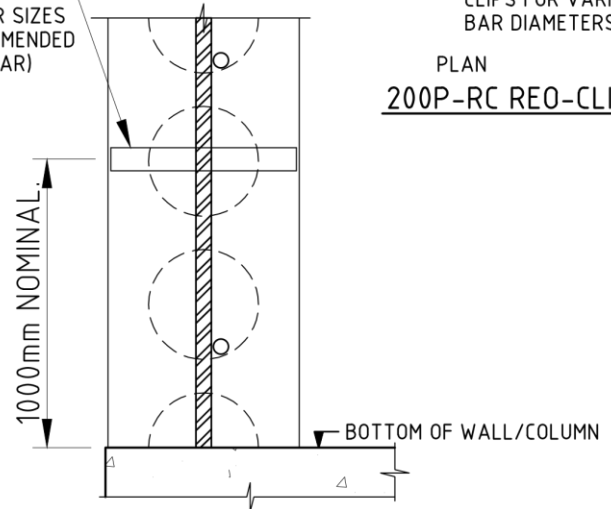
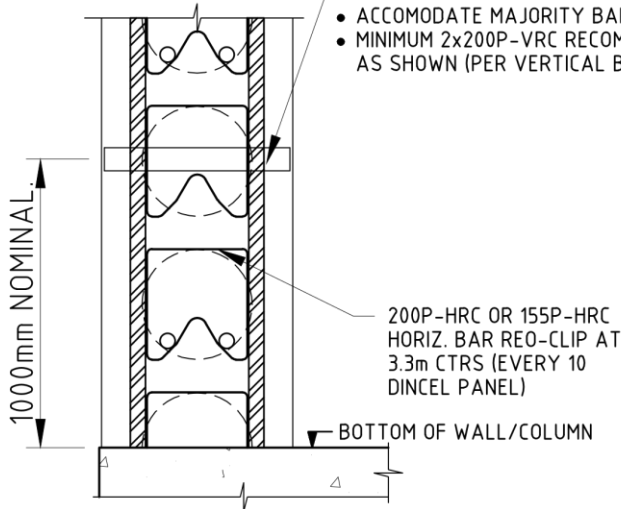
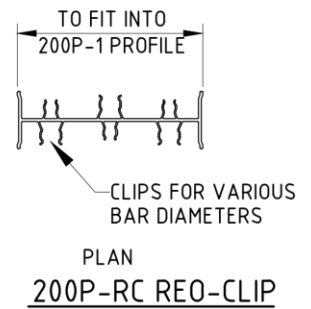

OPTION 1

BARS AT BOTH FACES WITH DOUBLE HORIZ. BARS

OPTION 2

BAR AT THE CENTRE

REINFORCEMENT BAR POSITIONING DETAILS

155P-HRC OR 200P-HRC HORIZONTAL BAR LOCATORS

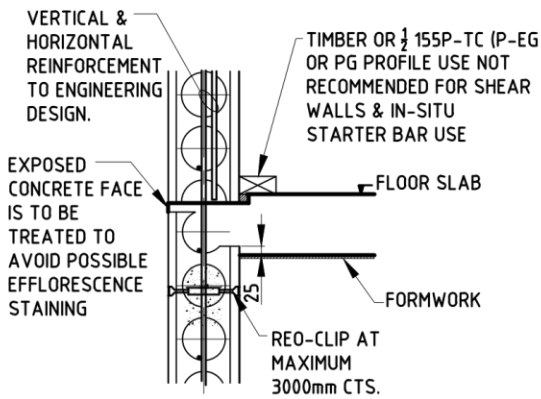

DETAIL 4

SHEAR WALL OPTION - 2
NO P-EG OR P-G ALLOWED AT SHEAR WALLS

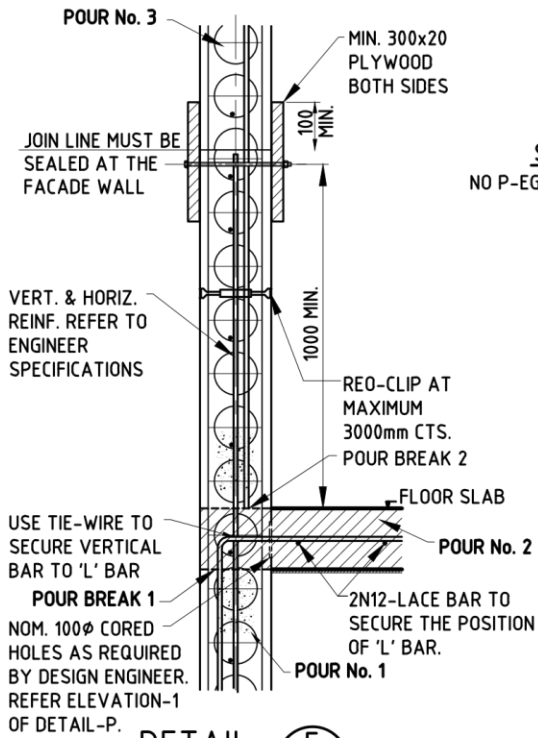

DETAIL 5

SHEAR WALL OPTION - 1

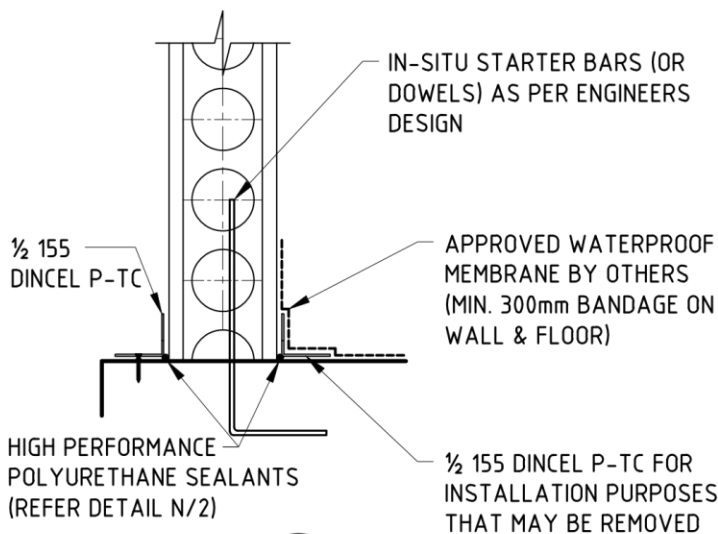

DETAIL 1

DETAIL 1 IS ONLY RECOMMENDED WHERE FOOTING IS ABOVE THE PERMANENT WATER TABLE (REFER 275 DINCEL MANUAL FOR ALL SUBMERGED CONDITIONS)

DETAIL S TYPICAL LIFT SHAFT AND SHEAR WALLS

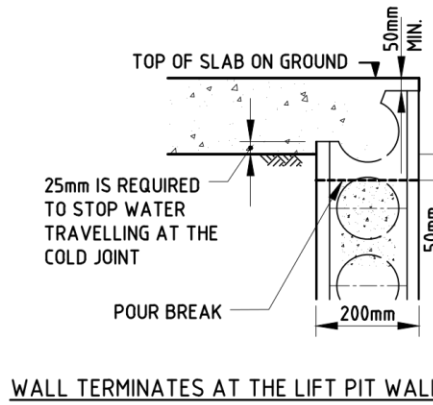

DETAIL 3

ALTERNATIVE TO DETAIL 2

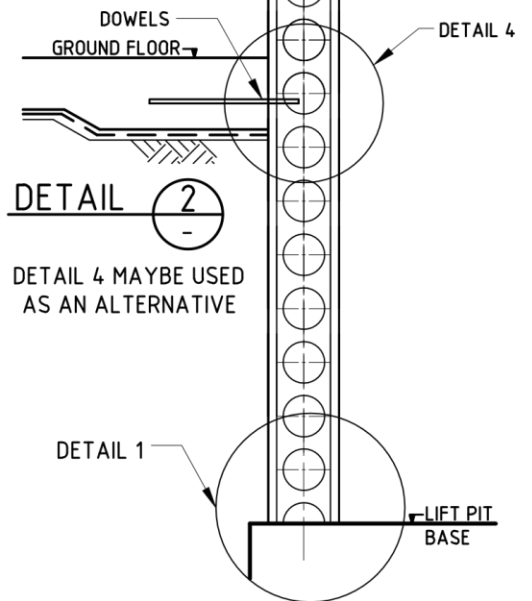

DETAIL 2

DETAIL 4 MAYBE USED AS AN ALTERNATIVE

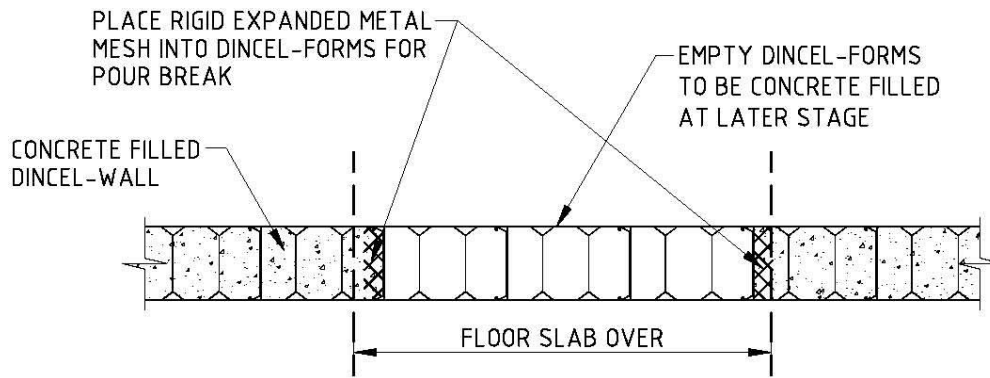

DINCEL-WALL AT FLOOR SLAB
POUR-STRIP

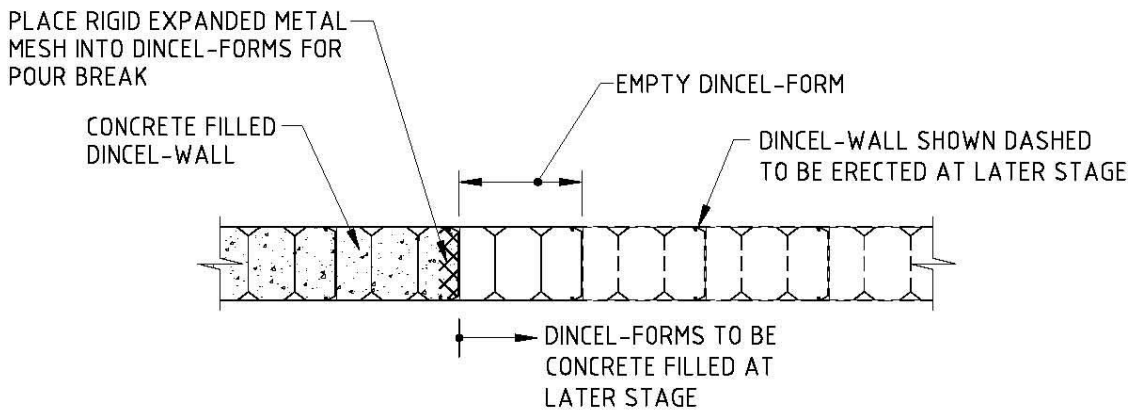

HOW TO STOP & START
CONCRETING AT DINCEL-WALL

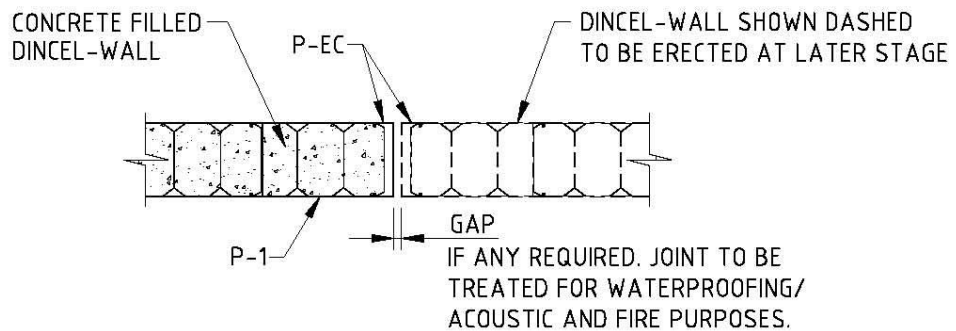

HOW TO STOP & START
CONCRETING AT DINCEL-WALL